

THE MAGAZINE FOR CONSUMER ELECTRONICS SERVICING PROFESSIONALS

# ELECTRONic™

Servicing & Technology

JUNE 1989/\$2.50

**This is an analog scope? • HDTV proposal meets all key criteria**

**Servicing the RCA CTC107 color TV — Part II**



Circuit tracing

AN INTERTEC PUBLICATION

[www.americanradiohistory.com](http://www.americanradiohistory.com)

# Find The Defective Capacitors, Coils, Resistors, SCRs And Triacs That All Other Testers Miss . . .

Presenting a new, improved, dynamic and mistake proof LC Analyzer that finds defective components all other testers miss.

- Dynamically tests capacitors for value from 1 pF to 20F, leakage with up to 1000 volts applied, dielectric absorption and equivalent series resistance (ESR).

- Dynamically tests inductors, in-or-out of circuit, from 1 uH to 20 Henrys for opens, shorts, value, and detects even one shorted turn.

- Dynamically tests SCRs, Triacs, High Value Resistors, and locates the distance to within feet of an open or short in a transmission line for an added bonus.

- Automatically makes all of the tests, compares them to EIA (Electronic Industries Association) standards and reads the results as Good or Bad. Enter all information right from the component without look-up charts, calculations, or errors.

- Extends your testing capability to places where an AC cord won't reach, with rechargeable 9 hour battery or AC operations.

- An added feature alerts you that the fuse has opened, and that there may be residual high voltage on the component under test.

**New!**  
And Improved!



It's like having your own Standards Engineer with you at all times.

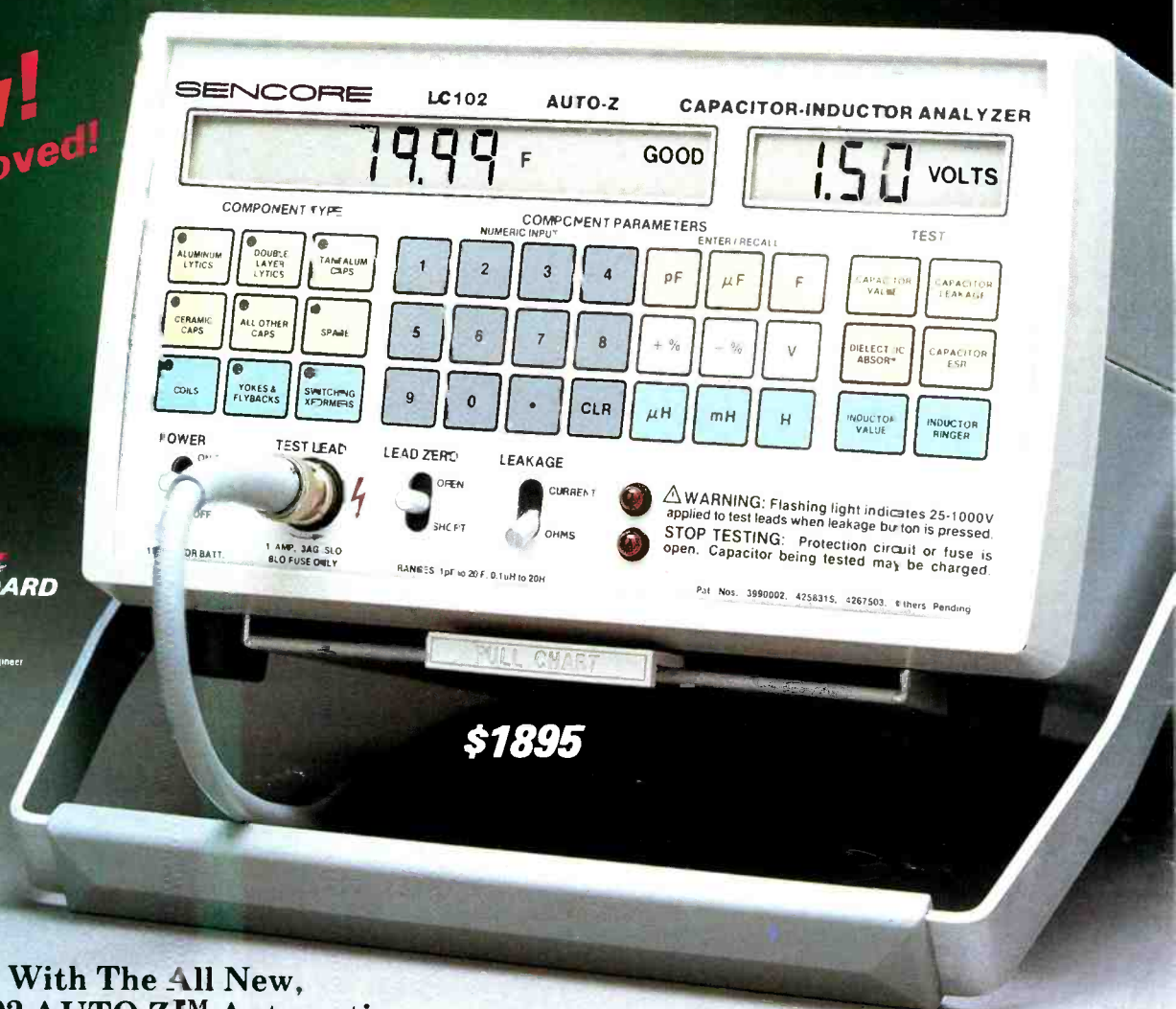

**\$1895**

With The All New,  
LC102 AUTO-Z™ Automatic  
Capacitor-Inductor Analyzer.  
Four Patents

**Call 1-800-SENCORE**  
In Canada Call 1-800-851-8866

Circle (1) on Reply Card

# The Troubleshooting Guides with Vision

*When VCR problems bring your service department to a standstill, turn to your Mitsubishi VCR Troubleshooting Guides! This intensive two tape collection of troubleshooting information features Mitsubishi's on-screen indexing system for easy symptom analysis and efficient troubleshooting.*

*The techniques explored are easily adaptable and can be applied to a wide range of VHS VCR brands. The VCR Troubleshooting Guides are a continuous source of reliable information that saves time, money and headaches.*

*If troubleshooting has got you down, look up to the experience of the easy-to-follow Mitsubishi Troubleshooting Guides.*

*Turn your service department down-time into up-time, today!*



**MITSUBISHI**  
ELECTRIC SALES AMERICA, INC.

## VCR TROUBLESHOOTING GUIDES

TT-103 VOLUME I - Tape Transport, Signal Paths and Servos .....\$49.95  
 TT-108 VOLUME II - Mechanical Control, Cassette & Tape Loading/Unloading...\$49.95  
 TT-109 VOLUMES I & II .....\$95.00  
 PRICES INCLUDE WORKBOOKS - Additional WORKBOOKS.....\$4.95 each

COD ORDERS ACCEPTED (800) 553-7278 • FAX (800) 825-6655

VISA/MC ACCEPTED

Circle (3) on Reply Card

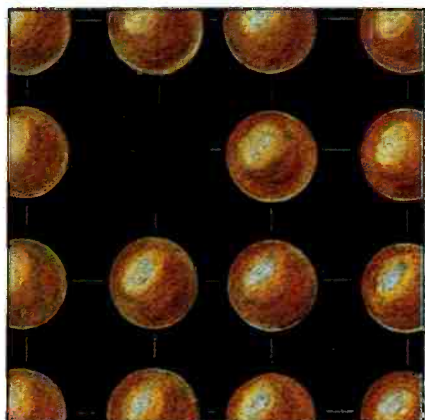

Page 10

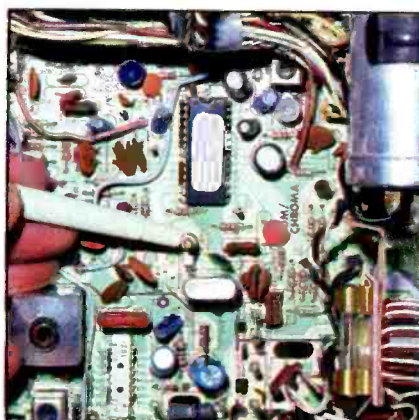

Page 24

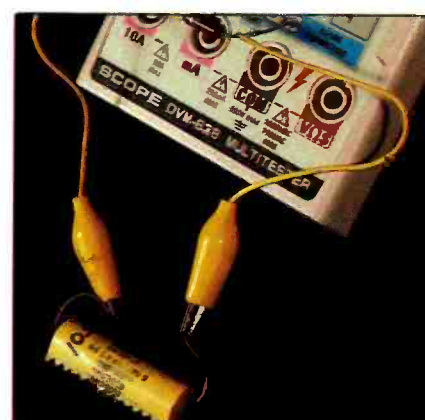

Page 46

## FEATURES

### 10 Circuit Tracing

By Robert G. Mousseau

Someone brings in a TV brand you've never heard of and you don't even know where it was manufactured, let alone have a manufacturer-produced schematic. What do you do — send the customer away (probably forever) or try to fix it anyway (probably unsuccessfully)? You have one other option: Trace the circuit you suspect the problem is in and make your own schematic. Don't panic — it may not be as tough as it sounds.

### 24 Servicing the RCA CTC107 Color TV — Part II

By Homer L. Davidson

Part I of this article introduced this model of TV. This conclusion will focus on trouble symptoms caused by one defective luminance/chrominance IC. This one little IC can cause flashing and distorted pictures, excessive brightness, retrace lines, shutdown, incorrect color hues, loss of color, intermittent color...quite a list.

### 42 This Is an Analog Scope?

Do you have an analog scope or a digital scope? If you answered *analog* and it's a recent model, you might be in for a surprise — a lot of the circuitry in your analog scope might actually be digital. When you're measuring repetitive waveforms, digital might seem like the only way to go, but many modern analog scopes are also making strides toward simpler, faster operation.

### 56 What Do You Know About Electronics?

Quiz Feedback

### 59 Business Corner

Choosing the Right Software

### 60 Audio Corner

Audio Output Problems? Maybe It's ESR

### 62 Computer Corner

Some Hints and Tips for IBM PCs

### 63 Books

### 64 Video Corner

Record Problems? Check the Safety-tab Switch

### 66 Readers' Exchange

### 68 Advertisers' Index

## DEPARTMENTS

### 4 Editorial

Tracking Down Elusive Information

### 6 News

### 22 Test Your Electronics Knowledge

### 31 Profax

### 46 Report from the Test Lab

The Scope Model DVM-638

### 53 Products

### 54 Technology

HDTV Proposal Meets All Key Criteria

## ON THE COVER

Even when schematics for particular electronic devices aren't available, if the servicer knows what the different component symbols are and what function the components themselves play, tracing the circuit can allow him to draw his own schematic. (*Concept and design by Barbara Miles, graphic designer.*)

# LEADER

CARVER DENON harman/kardon  HITACHI  
NEC ONKYO  PIONEER  SANSUI  
SHARP SONY  TEAC YAMAHA

## These leaders specify Leader.

When servicing electronics, depend on Leader for your test equipment needs.

Leader meets the standards of so many, because we set such high standards in design.

Equip your bench with our standard test equipment as required by manufacturers. Leader continually consults manufacturers and their service facilities to determine what products and features you'll need. The unique features on Leader equipment help you work smarter and increase efficiency.

SEE LEADER INSTRUMENTS AT ELECTRO '89, BOOTHS 1663-1667

You'll find hard-to-beat capabilities and value throughout the Leader line.

See all there is to Leader's leadership, and benefit from our more than 34 years of experience. Phone now to discuss your equipment requirements, for a copy of our catalog, and for the name of your nearest "Select" Leader Distributor. All Leader equipment is backed by a TWO-YEAR WARRANTY, and factory service on both coasts.

Call toll-free  
**1 800 645-5104**  
In NY State  
**516 231-6900**

Leader Instruments Corporation  
380 Oser Avenue, Hauppauge, New York 11788  
Regional Offices:  
Chicago, Dallas, Los Angeles, Boston, Atlanta  
In Canada call Omnitronix Ltd. 416 828-6621

## LEADER

FOR PROFESSIONALS WHO KNOW  
THE DIFFERENCE

1. LCG-400S NTSC Pattern Generator
2. LVS-5850B NTSC Vectorscope
3. LDC-823S 250-MHz Frequency Counter
4. LMS-238 TV Stereo Generator
5. 3216 AM/FM Stereo Generator
6. LHM-80B High Voltage Meter

7. LSW-333 TV Sweep Generator
8. LAG-126S Audio Generator
9. LMV-185A AC Millivoltmeter
10. LFM-39A Wow & Flutter Meter

11. LDM-171 Distortion Meter
12. LTC-906 Transistor Checker
13. LDM-853A Digital Multimeter
14. LPS-152 DC Power Supply
15. LPM-8000 Laser Power Meter
16. LBO-2060 CRT Readout Oscilloscope

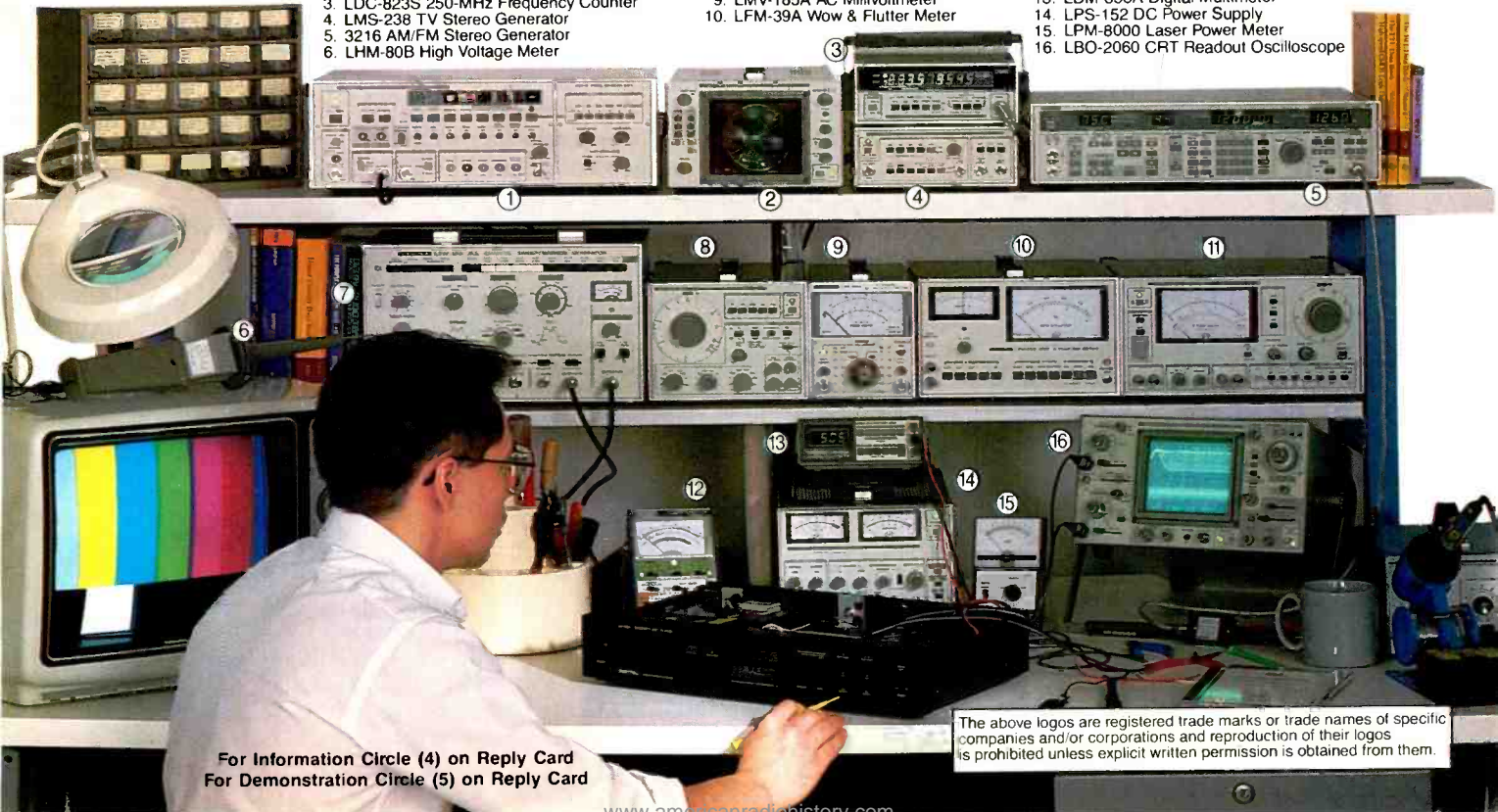

For Information Circle (4) on Reply Card  
For Demonstration Circle (5) on Reply Card

The above logos are registered trade marks or trade names of specific companies and/or corporations and reproduction of their logos is prohibited unless explicit written permission is obtained from them.

# Tracking down elusive information

I get some interesting letters from readers. Just today (it's April 20 as I write this) I received a letter from a reader who has a MultiTech VCR in for repair. The letter states, "I have a VCR for servicing but cannot find any schematic for it. The make of this VCR is MultiTech model MV-089. I hope you can give me some information or know someone who knows about this VCR brand."

I researched both the most recent Consumer Electronics Show Guide and the latest Howard W. Sams Photofact index. Nothing.

This is a common problem. Not too long ago I received a letter from someone looking for a television set with the brand name Conic. Never heard of it.

In still another letter, a reader asked for information on a Dumont TV set. A little research revealed that the company was actually no longer a manufacturer, but was selling sets made by several manufacturers in Asia under the Dumont brand name. In this case, the only way to get servicing information on a Dumont set was to contact the brand-name seller with a model number. That company would, in turn, give the caller the name of the company that actually manufactured the set. Then the individual who needed the information could call or write to the manufacturer for servicing literature.

There seems to be an epidemic of this kind of thing, and it's a real problem. In so many cases, when the set is brought in for service, the servicer has no idea where to get information.

We'd like to try to improve this situation. If we can get the cooperation of a lot of our readers, perhaps we could

act as a kind of information clearing house. Here's what we propose: If you have any kind of consumer-electronics product in for servicing and you just can't find any servicing information on the product, let us know. We will publish the request for information, asking readers who know where to find this information to provide us with it.

If a reader is able to provide the information, we'll publish it in a future issue of the magazine. If we get enough of this kind of information, we might even be able to make it a regular department, listing all of the sources of information on the little-known brands on a monthly basis, adding and deleting as the situation warrants. Otherwise, we'll just publish the updates in the News department.

Let's start the ball rolling right now. If you're stymied in the repair of a set because you can't find the servicing information or even locate the company who made the set, drop us a line. We'll try to find someone who knows. If you've spent a lot of time and effort locating information on some obscure set, please share that information with the rest of us. Through a cooperative effort, we might be able to make life a little easier for all servicing technicians, plus improve the level of service to the public.

*Nile Conrad Persson*

Mail to:  
Conrad Persson  
Electronic Servicing & Technology  
P.O. Box 12901  
Overland Park, KS 66212

## REQUEST/SOURCE FOR INFORMATION

Name \_\_\_\_\_  
Street \_\_\_\_\_  
City \_\_\_\_\_ State \_\_\_\_\_ Zip \_\_\_\_\_  
Telephone number \_\_\_\_\_

Information requested/provided: \_\_\_\_\_

Model/part number \_\_\_\_\_  
Manufacturer \_\_\_\_\_

Where have you checked? \_\_\_\_\_  
\_\_\_\_\_

**FLUKE**



**PHILIPS**



The new 80 Series is a digital meter, an analog meter, a frequency counter, a recorder, a capacitance tester, and a lot more.

It's the first multimeter that can truly be called "multi" ... not only standard features, but special functions usually limited to dedicated instruments.

Plus, innovations only Fluke can bring you. Like duty cycle measurements. Or recording the minimum, maximum *and* average value of a signal. Or the audible MIN MAX Alert™ that beeps for new highs or lows.

There's even Fluke's exclusive Input Alert™, that warns you of incorrect input connections. And a unique Flex-Stand™ and protective holster, so you can use the 80 Series almost anywhere.

Make sure your next multimeter is truly multi. Call today at **1-800-44-FLUKE, ext 33.**

FROM THE WORLD LEADER IN DIGITAL MULTIMETERS.



FLUKE 83	FLUKE 85	FLUKE 87
Volts, ohms, amps, diode test, audible continuity, frequency and duty cycle, capacitance, Touch Hold®, relative, protective holster with Flex-Stand™.	Volts, ohms, amps, diode test, audible continuity, frequency and duty cycle, capacitance, Touch Hold®, relative, protective holster with Flex-Stand™.	Volts, ohms, amps, diode test, audible continuity, frequency and duty cycle, capacitance, Touch Hold®, relative, protective holster with Flex-Stand™.
\$189*	\$219*	\$259*
0.3% basic dc accuracy	0.1% basic dc accuracy	0.1% basic dc accuracy
5 kHz acV	20 kHz acV	20 kHz acV
Analog bargraph & zoom	Analog bargraph & zoom	High resolution analog pointer
Three year warranty	Three year warranty	True rms ac
		1 ms PEAK MIN MAX
		4½ digit mode
		Back lit display
		Three year warranty

\*Suggested U.S. list price

The new Fluke 80 Series shown actual size

John Fluke Mfg. Co., Inc., P.O. Box C9090 M/S 250C, Everett, WA 98206  
 U.S.: 206-356-5400 CANADA: 416-890-7600 OTHER COUNTRIES: 206-356-5500  
 © Copyright 1988 John Fluke Mfg. Co., Inc. All rights reserved. Ad No. 0581-F80

Circle (6) on Reply Card

**FLUKE**

## UL publishes transformer standard

Underwriters Laboratories (UL) is seeking comments from individuals and organizations interested in helping develop the first edition of the Standard for Safety for High-frequency Transformers for Use in Audio-, Radio- and Television-type Appliances, UL 1877.

The standard will cover transformers intended for use in high-frequency, switching-type appliances in which the primary winding is connected across the supply circuit. These requirements also apply to the associated primary and secondary circuitry necessary for the operation of the transformer.

To request your free copy of a proposed draft, contact Barbara Dorfman at UL, 1655 Scott Blvd., Santa Clara, CA 95050.

## NCI lobbies for decoding

The National Captioning Institute (NCI) has released a resolution of its Corporate Advisory Council that calls for TV manufacturers to build closed-caption decoding capability into new TVs by 1991.

The resolution states, "Technology is now available to enable the decoder circuitry to be built into new television sets," and "the availability of decoder-equipped television sets could significantly increase the audience served by the closed-captioned television service."

For more information on NCI, contact the Office of Public Affairs and Development, The National Captioning Institute, 5203 Leesburg Pike, Suite 1500, Falls Church, VA 22041; 703-998-2416.

## EIA publishes report

U.S.-manufactured color TVs accounted for almost 70% of the total number of color TVs sold to consumers in 1987 — 13.4 million sets worth \$5.3 billion in retail value, according to a report by Robert R. Nathan Associates (RRNA) for the Electronic Industries Association (EIA).

The report, titled "Television Manufacturing in the United States: Economic Contributions — Past, Present and Future, Chapters I-III," examines the impact of U.S. color TV manufacturing on the economy.

The report contained the following highlights:

- Twenty companies currently manufac-

ture color TVs in 35 U.S. cities.

- U.S. production of virtually all of the TV sets 20 inches and larger are sold in the United States.
- 50% of all the 13-inch to 19-inch color TVs that are sold in the United States are produced in the United States.
- Growth in color TV manufacturing's contribution to the U.S. economy was 17.5%, from \$15.4 billion to \$18.1 billion from 1980 to 1987.
- TV manufacturing today generates 240,000 jobs in the TV industry.

For more information on the report, contact the HDTV Information Center, 1722 Eye St. N.W., Suite 200, Washington, DC 20006; 202-457-4992.

## Panasonic announces accessories distributors

Panasonic has announced that nine Midwest-based parts distributors have been authorized to distribute its newly introduced line of typewriter and telephone accessories. Authorized distributors are currently stocked to provide immediate shipment of accessories in bulk quantity. A Panasonic-designed racking program for small-quantity purchases is also available. For a map of authorized Panasonic accessory distributors, write to Panasonic, 425 E. Algonquin Road, Arlington Heights, IL 60005, Attn: Bob Kryzak.

## EIA publishes first-quarter figures

U.S. factory shipments of electronic equipment, components and related products totaled \$63.8 billion for the first quarter of 1989, excluding imports. This figure represents a 6.5% increase over the 1988 first-quarter total industry sales figures, according to estimated figures released by the Electronic Industries Association (EIA).

Other shipment figures and figures for percentage of change over 1988 include:

- communications equipment: 16,150 billion (2.6% increase).
- electronic components shipments: \$12.8 billion (9% increase).
- consumer electronics sector (including imports): \$7.4 billion (4% increase).
- U.S. factory sales of consumer electronics: \$1.2 billion.
- computers and industrial electronics: \$20.7 billion (6% increase).
- sales of other electronics-related products and services: \$12.9 billion (10% increase).

**Electronic Servicing & Technology** is the "how-to" magazine for technicians who service consumer electronics equipment. This includes service technicians, field service personnel and avid servicing enthusiasts who repair and maintain audio, video, computer and other consumer electronics equipment.

## EDITORIAL

Nils Conrad Persson, *Editor*  
 Carl Babcoke, *Consumer Servicing Consultant*  
 Tom Cook, *Senior Managing Editor*  
 Alisa Carter, *Associate Editor*  
 Pamela S. Fleener, *Editorial Assistant*

## CONSULTING EDITORS

Homer L. Davidson, *TV Servicing Consultant*  
 Christopher H. Fenton, *Circuit Fabrication Consultant*  
 Victor Meeldijk, *Components Consultant*  
 Kirk G. Vistain, *Audio Consultant*  
 Sam Wilson, *Electronics Theory Consultant*

## ART

Kevin Callahan, *Creative Director*  
 Barbara Miles, *Graphic Designer*

## BUSINESS

Cameron Bishop, *Group Vice President*  
 Eric Jacobson, *Group Publisher*  
 Greg Garrison, *Sales Manager*  
 Marcia Durrett, *Marketing Director*  
 Evelyn Hornaday, *Promotions Manager*  
 Kelly Hawthorne, *Promotions Coordinator*  
 Dee Unger, *Advertising Business Manager*  
 Catherine Grawe, *Advertising Coordinator*

## ADVERTISING

Regional advertising sales offices are listed in classified pages.

## ADMINISTRATION

R. J. Hancock, *President*  
 Chuck Rash, *Corporate Circulation Director*  
 Jane J. Powell, *Circulation Director*  
 Jo Ann DeSmet, *Fulfillment Manager*  
 Barbara Clare, *Reader Correspondent*



Member, Audit Bureau of Circulation



Member, American Business Press



Member, Electronic Servicing Dealers Association

## CORRESPONDENCE

Editorial, advertising and circulation correspondence should be addressed to: P.O. Box 12901, Overland Park, KS 66212-9981 (a suburb of Kansas City, MO); 913-888-4664. Home office fax: 913-541-6697. Home office telex: 42-4156 INTERTEC OLPK

**SUBSCRIPTION PRICES:** one year, \$19.49; two years, \$32.98 in the USA and its possessions. Foreign countries: one year, \$23.49; two years, \$36.98. Single copy price: \$2.50; back copies, \$3.00. Adjustment necessitated by subscription termination to single copy rate. Allow 6 to 8 weeks for new subscriptions.

**PHOTOCOPY RIGHTS:** Permission to photocopy for internal or personal use is granted by Intertec Publishing Corp. for libraries and others registered with Copyright Clearance Center (CCC), provided the base fee of \$2 per copy of article is paid directly to CCC, 21 Congress St., Salem, MA 01970. Special requests should be addressed to Eric Jacobson, publisher. ISSN 0278-9922 \$2.00 + 0.00

**Electronic Servicing & Technology** (ISSN 0278-9922) is published monthly for \$19.49 per year by Intertec Publishing Corp., 9221 Quivira Road, Overland Park, KS 66215. Second-class postage paid at Shawnee Mission, KS and additional mailing offices. POSTMASTER: Send address changes to ELECTRONIC SERVICING & TECHNOLOGY, P.O. Box 12960, Overland Park, KS 66212.

©1989 All rights reserved.





# PHILIPS

# THERE IS NO SMARTER CHOICE THAN PHILIPS ECG.



## ECG PR200A OR PR60: FOR THE RIGHT ANSWER TO YOUR SCOPE PROBE NEEDS.

ECG scope probes come packed with features and packed with value. Features on the PR200A include:

- 200 Mhz bandwidth capability
- X1, X10 attenuation and reference switch
- Low input capacitance
- Large thumb switch with positive detents, for easy switching between X1 and X10 and ground reference
- Comes with an IC tip, BNC adaptor, insulating tip and a retractable hook

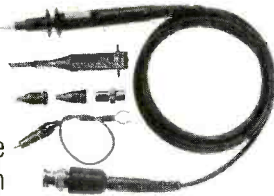

The PR60 features:

- 60 Mhz bandwidth capability
- X1, X10 attenuation and reference switch
- Retractable hook

ECG scope probes: the smart choice.

Circle (26) on Reply Card

## ECG REPLACEMENT PARTS KEEP VCR'S IN TOP SHAPE.

To replace VCR mechanical parts, look no further. Our full line can replace mechanical parts for all major brands of VCR's, and our catalog contains the most accurate cross-references by brand name, part number, and model number.

- Line includes 13 pinch rollers, 42 idler wheels and assemblies, 4 idler tires, and 48 belt kits
- Individual belts available



VCR mechanical parts from ECG: the smart choice.

Circle (27) on Reply Card

## ECG DM-26 AND DM-27 FULL FUNCTION GENERAL PURPOSE MULTIMETERS.

The ECG DM-26 and DM-27 multimeters are loaded with features and loaded with value. Just check out the array of capabilities:

- Diode test
- Rotary range switch
- Tilt stand
- 0.8% basic DC accuracy
- 3 1/2" digit LCD display, 0.5" high
- 20 MΩ full scale
- 10 MΩ input resistance, DC
- Low power Ohms
- Overload protected
- The DM-27 also includes an audible continuity test



ECG multimeters: the smart choice.

Circle (28) on Reply Card

## ECG CABLE CONVERTERS BRING IN THE SIGNAL LOUD AND CLEAR.



- The TV 2000 adapts any TV set to cable-ready
- Remote control adjusts volume, turns TV on/off, has direct channel selection and channel stepping
- Receives up to 139 VHF, UHF and cable channels
- Separate video and audio outputs for direct connection to VCR and stereo systems
- Stores up to 12 user-selected channels for quick selection

ECG cable converters: the smart choice.

Circle (29) on Reply Card

Contact one of more than 900 distributors or call 1-800-225-8326 for the name of the distributor nearest you. It just might be the smartest call you make all week.

## Philips ECG Company

A Division of North American Philips Corporation  
© 1989, Philips ECG Company.

# Digital scopes with a

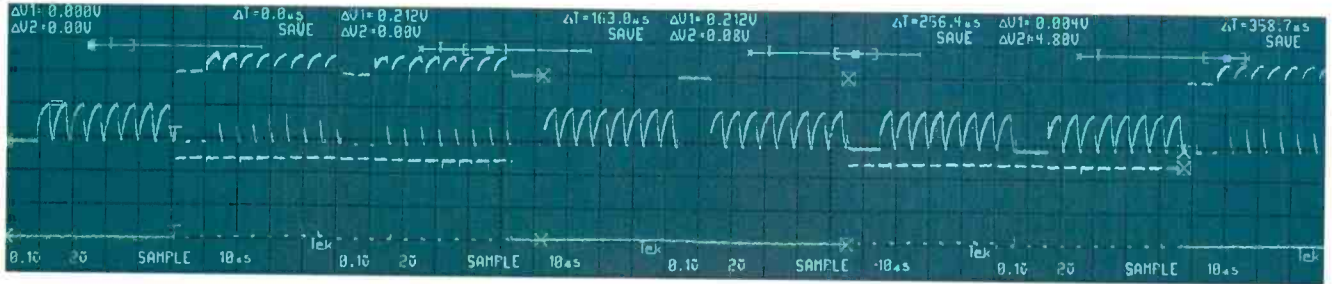

## Give up real-time capability for storage? Not with Tek!

That's because analog capability is integral to low-cost Tek digital storage oscilloscopes. So you need only one instrument to make all your measurements efficiently. With no trade-offs.

It's another Tek advantage: analog and digital in one familiar, affordable package.

Single-shot events.  
Elusive glitches.  
Low-speed  
phenomena.

*Four screen photos spliced end to end illustrate the benefit of full four-screen capture using the 2230's 4K record length.*

Any waveform can be viewed for as long as you like. Or stored in 4K of memory for later analysis or comparison to other waveforms. And if there's a question about a digital measurement, just push a button for real-time display analysis.

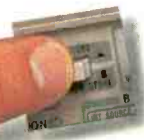

**Select either mode at the push of a button.**

With digital storage you can capture events which are difficult if not impossible to see on conventional scopes. Pre and post trigger events. Fast transients.



# real-time advantage.

## The affordable portables.

These are the world's best-selling digital storage oscilloscopes. And with the new 50 MHz Tek 2211 joining the family, there's now an even better selection—in bandwidth, performance and price.

Select for advanced features such as 100 ns glitch capture at any sweep speed, CRT readout, measurement cursors, multiple acquisition modes and hardcopy output, plus optional GPIB or RS-232-C interfaces and software.

These scopes are perfect for first-time digital users. And seasoned operators will appreciate even more their versatility, convenience and value. All backed

Features	2230	2221	2220	NEW 2211	2201
Bandwidth	100 MHz	60 MHz	60 MHz	50 MHz	20 MHz
Max. Sampling Speed	20 MS/s	20 MS/s	20 MS/s	20 MS/s	10 MS/s
Vertical Resolution	8-12 bits	8-10 bits	8 bits	8 bits	8 bits
Record Length	1K/4K Selectable	4K	4K	4K	2K
Glitch Capture	100 ns	100 ns	100 ns	No	No
CRT Readout/Cursors	Yes	Yes	No	Yes	No
GPIB/RS-232-C Options	Yes	Yes	Yes	Yes	Yes
Warranty	3-years on labor and parts including CRT				
Price	\$4995	\$3995	\$2995	\$2395	\$1495



Each scope offers a range of capabilities you'd expect to find only in much more expensive instruments.

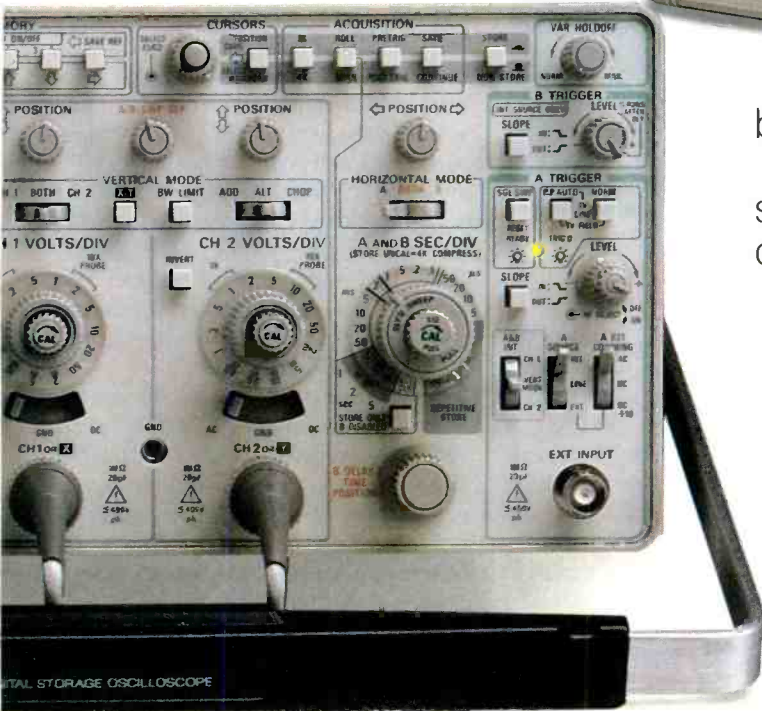

by Tek quality and a 3-year warranty.

Discover the potential. Let Tek show you what you're missing... without making you give up analog to see it. That's the real-time advantage of Tek digital storage.

For easy ordering or more information call Tek Direct:

# 1-800-426-2200



**Tektronix**  
COMMITTED TO EXCELLENCE

Circle (7) on Reply Card

# Circuit tracing

By Robert G. Mousseau

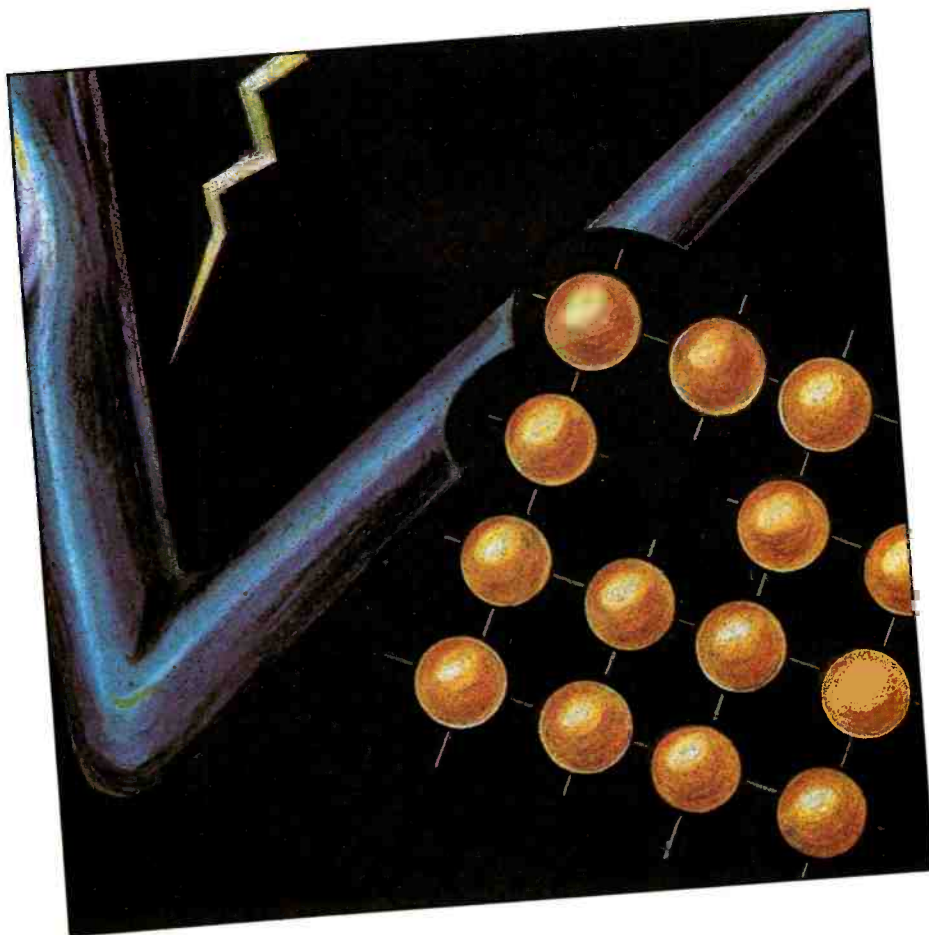

It's a scenario guaranteed to produce some " \*&\$#@#&\*%@!": You're faced with a malfunctioning electronics device, you don't have the schematic and you can't order one. You have three choices: You can refuse to service the unit; you can try flying blind, hoping you can track down the problem by inspection and random signal tracing; or you can localize the problem to an area of the circuit, then trace that portion of

---

Mousseau is the department head of electronics at the State Technical Institute and Rehabilitation Center in Delton, MI.

the circuit and create your own schematic diagram.

Actually, circuit tracing is performed for one of two reasons: to have a schematic available when the time comes that you need one, or to develop a schematic for troubleshooting. You will use one of two different approaches depending on what you wish to accomplish.

If you circuit-trace to troubleshoot, you will want to limit your tracing to a signal flow diagram. The signal flow diagram traces only the path required to get the signal from one stage to the

next. (See Figure 1.)

Once you have developed this diagram, you can apply power and follow the signal over the traced path. When you find the point where signal flow fails, you can troubleshoot by testing the active device and checking recognized circuit components. If this method is unsuccessful, you can develop a schematic of the problem area.

The point at which you begin tracing depends on how well you have localized the problem. If the problem is in a particular section, you will want to trace only that section and, if you can isolate it further, to a smaller area still. The better you do at localizing, the less time you will spend in tracing.

The approach is different if you want a complete schematic of the device or section for reference purposes, but the process and procedures are the same.

Circuit tracing is possibly the single most difficult task faced by the electronics technician. Given today's technology and circuits, it is difficult, time-consuming and taxing to the individual's technical knowledge. With the proper equipment and organization, circuit tracing can, however, be much less difficult and time-consuming than you think. In fact, as your skills mature and you achieve success, circuit tracing can be very rewarding.

Developing your skill in circuit tracing has many benefits. It will increase your knowledge of circuit wiring techniques, component physical characteristics, board layout strategies, numbering systems, basic circuit configurations, system concepts and electronics theory. You will also become more adept at researching components, reading diagrams and recognizing circuits. In fact, given today's disposition toward board and/or chip replacement rather than component-level troubleshooting,

you may need to circuit-trace or develop some similar challenge to maintain or increase your technical proficiency.

### Getting organized

The key to successful circuit tracing is proper preparation. Obtain the proper equipment and make appropriate preparations before you begin. Some useful items to have on hand:

- *Reference texts.* Basic electronic texts showing circuit configurations for transistors and integrated circuits is a must when circuit tracing. You'll refer to these books many times to help you structure a circuit in an appropriate manner. You'll also use them to identify the function of various circuits, including integrated circuits, which have many forms and functions.

- *Cross-reference catalog.* You need a manufacturer's reference or a cross-reference manual, such as the Phillips ECG or RCA SK cross reference, to identify the transistors or ICs on the board you are tracing and to determine their basing configuration (pinout). If you are fortunate, the reference will also provide a block diagram of the internal function of the ICs. Another reference is the IC Master catalog and the D.A.T.A. Digests.

- *High-intensity lamp.* A good light source is necessary for circuit tracing. The lamp is used for illumination but has another purpose: If the circuit board is translucent enough, which is often the case, the light from the lamp will let you see the foil pattern from the component side of the board. Circuit tracing is much easier using this approach. The lamp ideally should be mounted on a goose neck and sharply focused to provide a concentrated light source. For viewing purposes, a magnifying lens is sometimes preferred, particularly if you are working on a board involving

surface-mount components or closely packed circuitry.

- *Sharp, pointed probe.* When circuit tracing, you are constantly reversing the board, front to back, to determine the type and value of components connected to the foil. The sharp pointed probe is pressed against and anchored to the foil side of the board so that you don't lose your place in the reversing process. A really good, multipurpose probe that you can use for circuit tracing is a test probe with a phonograph needle insert. The hard metal point of the needle does not get dull, and it will stick in the soldered trace. If you run an insulated wire through the probe and connect a  $0.01\mu\text{F}$  capacitor to the open end, it can be used for circuit tracing. If you connect the ground clip of a meter ahead of the capacitor, the probe can be used to measure between two points on a circuit board. If a device lead is connected

after the capacitor, it can be used as a probe to isolate or inject.

- *Digital multimeter.* An ohmmeter is needed to verify through-board connections or the connections of coils, transformers or other multipin components. The meter should be accurate for measuring low resistance values. Economy DMMs are often inaccurate when used for measuring low resistance, and they can produce confusing results. Be certain that your meter is reliable. The voltage range is also occasionally used to measure and verify a circuit connection after voltage has been applied to the board being traced.

- *Soldering iron and hand tools.* You'll need the hand tools and soldering iron to cut wire, remove boards and often to remove components so you can make isolated measurements. The soldering iron should be line-isolated and have a grounded tip, because you will be

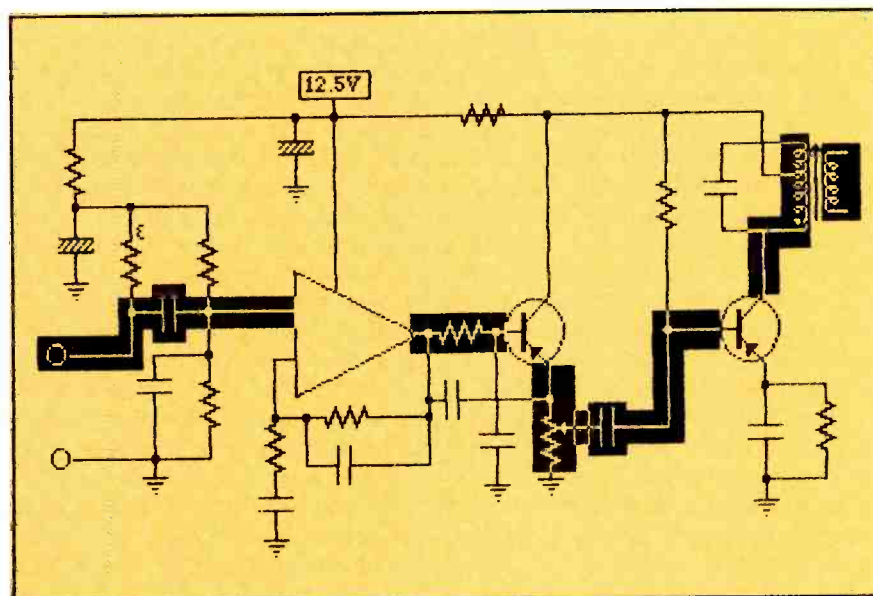
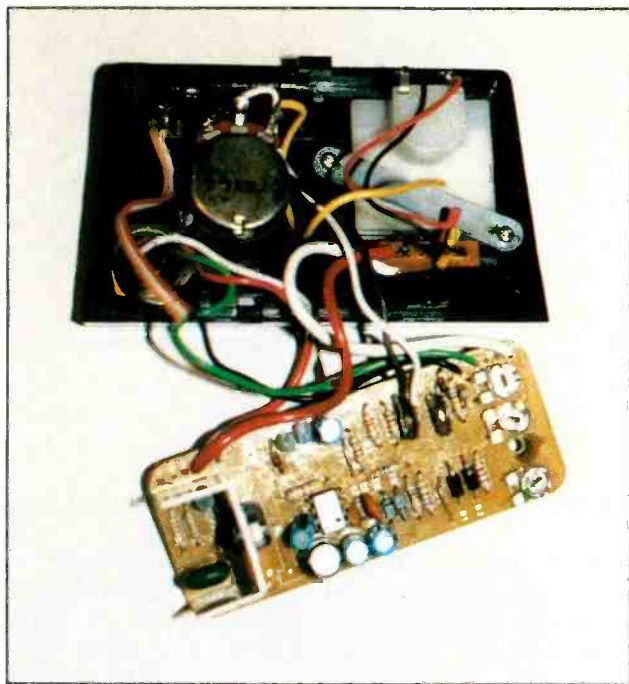
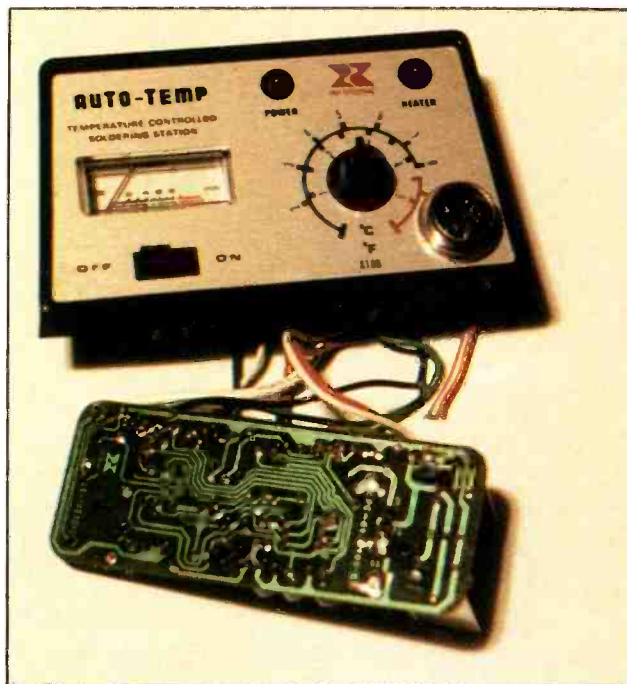

Figure 1. The signal flow diagram traces only the path required to get the signal from one stage to the next.



This electronically controlled soldering unit failed, and we couldn't obtain a schematic diagram, so we traced out the circuit for ourselves.



This is what the foil side of the printed-circuit board looks like.

soldering and unsoldering MOSFET devices.

- *Pencil and paper.* You will need plenty of paper when circuit tracing. You will frequently reorganize the schematic you are making to re-establish your focal point and to determine the overall concept of the circuit.

- *Magic marker.* A marker or similar item should be used to color the  $V_{CC}$  and ground foils.

### Component layout diagram

In this article, we'll be circuit-tracing the XYTRONIC model 168-2C temperature-controlled soldering station. Before you begin circuit tracing, make a component layout diagram of the board you are about to trace. Figure 2 shows a component layout diagram for the soldering station. The drawing should show the approximate location of all components and the connecting point of each wire routed to or from the board. Use care to draw the components in their proper locations. List the color and size ("small white," "large white," etc.) of each wire. Don't assign numbers to the components yet. Show pin 1 of all ICs by placing a dot at the pin 1 location. These steps will save time later in the circuit trace.

The component layout diagram should be a reasonably accurate presentation of the board. This diagram will

be used to identify and number components as you circuit trace. The letters and numbers below the diagram (covered in a later paragraph) represent resistors, capacitors or other components and will be used to number individual components. When you make this drawing, keep one thing in mind: This drawing may be used by you or another technician to troubleshoot. It should be as accurate as possible.

### Isolating the board

If you are tracing a circuit board connected to another board or to the chassis, it is best to remove the board. If you don't, the constant twisting of the board will break connection wires and it will be difficult to locate the proper connecting points. It also makes tracing more difficult if you are encumbered with wires that seem to always be in the way of what you are trying to do.

You will want to know the proper connection for the wires removed, so cut each wire about 1/2 inch to 1 inch above the connection. The pigtail remaining on the board will provide a color code so that you can reconnect the wires to the proper terminals. This procedure, together with the component layout diagram already prepared, should help assure that the wires will be placed on the proper terminal when tracing is complete. Be sure to follow through on

both techniques because the insulation occasionally slips off the pigtail during the circuit-tracing process.

### Component identifiers

You should identify and label each component on your component layout diagram as it is traced on the board. Labeling serves two purposes: It identifies each component and it shows which components you have already traced and recorded on your diagram. If the board you are tracing has component identifiers (numbers) already marked on the board, you may want to use these numbers. It may be difficult to obtain these numbers, however, because they are sometimes located beneath the component and are difficult to read without removing the component. If they are difficult to obtain, ignore them and assign your own number to the component.

When first learning to circuit trace, you should assign new numbers even if the board already has numbers. It tends to be less confusing to the beginner.

If you choose to renumber the components on the board or if the board does not have component identifiers, determine the type of components located on the board (resistors, capacitors, etc.). Immediately below the component layout diagram, show a letter (R, C, L, T, etc.) for each type of

# DOUBLE EXPOSURE

# DOUBLE EXPOSURE

1/2-page or Larger Ad:  
August ES&T



1-Time Rental:  
Up To 10,000 Names Off  
Our Circulation List!

Reach Two Audiences  
For the Price of One!

1. Your August message reaches ES&T's 45,000 readers. Show your prime customers what you've got to offer!
2. Then, with your FREE rental list, pinpoint the precise audience that needs your products and services. Target them now with your direct-mail efforts!

**You Choose Who, What, Where  
and Even When!**

You select the names you want by job title, type of business or geographic location. And you have a whole year to use them.

**Don't miss this 2-for-1 offer! Reserve your space today in the August ES&T. For more details, call Greg Garrison at 913-888-4664.**

THE MAGAZINE FOR CONSUMER ELECTRONICS SERVICING PROFESSIONALS

# ELECTRONIC

Servicing & Technology

An Intertec Publication

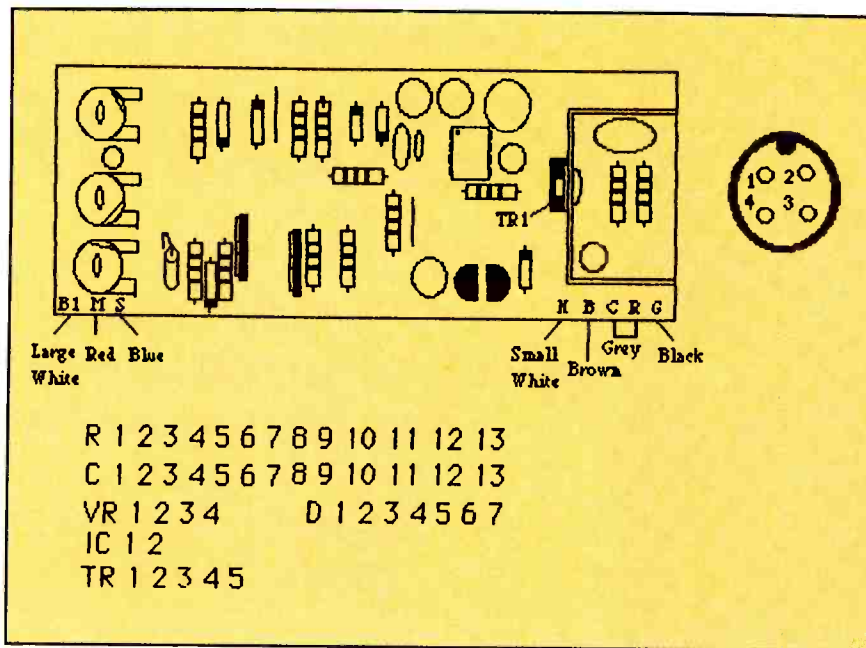

**Figure 2.** The component layout diagram should show the approximate location of all components and the connecting point of each wire routed to or from the board. This diagram will be used to identify and number components as you circuit trace.

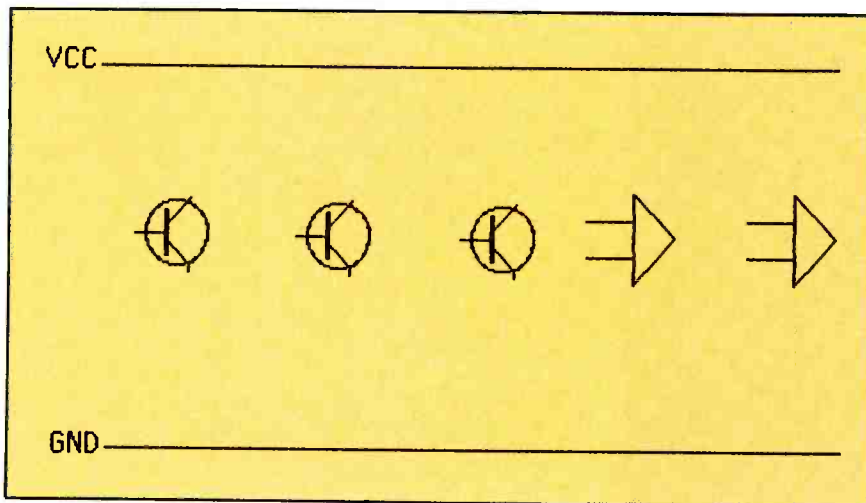

**Figure 3.** The preliminary grid should show all or a portion of the transistors or ICs on the board you are about to trace. A grid acts as a guide when you are circuit tracing because it helps you recognize when you have reached the end of a particular trace.

component (see Figure 2) followed by a series of numbers equal to or greater than the quantity of that type of component on the board. As you circuit trace, you will encounter different components. As you encounter each type of component, you should draw it on your schematic and label it with an identifier taken from the number sequence for that component. Also record that number on that component on the layout diagram. You should then strike that number from the sequence to ensure that you do not use it again.

Using the cross-reference catalog, determine the pinout of each active device on the board to be traced. Draw the diagram and pin numbers or identifying letters on a separate sheet of paper or the sheet containing the component layout diagram. If you are unable to identify an active device, don't be alarmed. You can often determine the pinout of the device while circuit tracing or during reorganization of the diagram. At the least, you will then know the input and output of the device and may be able to determine its func-

tion based on this information. Components can be cross referenced as they are located during tracing, but it slows down the process and disrupts the rhythm you have developed.

### Preparing a preliminary grid

A preliminary grid, as shown in Figure 3, can be prepared prior to circuit tracing. This grid should show all or a portion of the transistors or ICs on the board you are about to trace. If there are a large number of active devices, you may prefer to limit the number on the preliminary diagram to permit room for drawing the schematic.

Some technicians prefer to structure the grid as the schematic is developed, especially if the device is complicated and you anticipate having to frequently reorganize your drawing. A grid acts as a guide when you are circuit tracing because it helps you recognize when you have reached the end of a trace.

You will note that the grid of the soldering station, shown in Figure 3, has  $V_{CC}$  at the top and GROUND at the bottom. The grid is labeled this way for a specific reason. When you are circuit tracing, each circuit is completed when it is traced to ground,  $V_{CC}$  or the input to the following stage. The grid serves as a reminder that the circuit has been traced to a terminal point. When a grid is not used, the circuit is sometimes traced through  $V_{CC}$  or ground into another stage. The consequence is disastrous when it comes time to identify the type or function of the circuit.

### Familiarize yourself with the board

Before you begin circuit tracing, it pays to become familiar with the board and the location of various components. If the board has component identifiers provided, so much the better. It simplifies circuit tracing as it should identify the sequence in which the components are used. For example, Q1 would logically be in the circuit ahead of Q2 and higher numbered transistors. Similarly, IC2 should follow IC1. Resistors and capacitors should also follow a logical numbering sequence.

If you are tracing a more complex device, you may find that each section of the device has a definitive numbering sequence. For example, the 100 series components may be the input circuit while the 400 series components could be the output circuit. If component identifiers are provided, it might pay to identify the different numbering



# Quick relief for the IC testing blues...

ATE?  
LOGIC ANALYZERS?  
SCOPES?



## B&K-PRECISION's 560 now has user-programmable software to test even more ICs

Forget the headaches of complex and inaccurate IC test methods. Now B&K-PRECISION offers instant relief... the 560 Programmable IC Test System and AK-560 user programmable software.

The 560 tests over 90% of the most popular TTL and CMOS digital ICs, up to 24 pins, including counters and flip-flops—in circuit or out. The 560 speeds testing so much that it could pay for itself in just months.

The new software is menu driven and easy to use. It runs on an IBM PC, XT or AT or compatible and allows the 560 to be pre-programmed to test custom ICs or ICs not already in the extensive library. Once the new IC data has been downloaded to the 560, the PC is no longer required.

Testing is straightforward... Plain-English user prompts and test results simplify operation, and greatly

speed-up training of new personnel.

Key in a stored IC number, place an out-of-circuit IC in the ZIF socket and press "Test." You'll instantly see a "TEST GOOD" or fault display by pin number. Results can be sent to a printer via an RS-232 port.

In-circuit tests are similar. For testing in-circuit ICs not covered by standard out-of-circuit test patterns, the 560 can "learn" from a known good board. This exclusive feature eliminates the problems of conventional testers, where "good" ICs frequently test "bad" on in-circuit tests.

The 560 also checks itself.

Every time you switch-on, a diagnostic program scans its memory, the CPU and all pin drivers

For in-circuit tests, you can program-in all IC's on a board for superfast trouble-shooting, in-plant or at maintenance depots—by unskilled personnel.

It can drastically reduce board float.

Out-of-circuit, the 560 can perform fast incoming inspections or QC tests.

THE B&K-PRECISION 560 is the right prescription for your IC testing blues. Relief is just a phone call away!



**BK PRECISION**  
MAXTEC INTERNATIONAL CORP.

6470 West Cortland Street, Chicago, Illinois 60635  
312/889-1448

International Sales,  
6470 W. Cortland St.,  
Chicago, IL 60635  
Canadian Sales,  
Atlas Electronics Ontario  
South and Central  
American Sales,  
Empire Exporters,  
Plainville, NY 11803

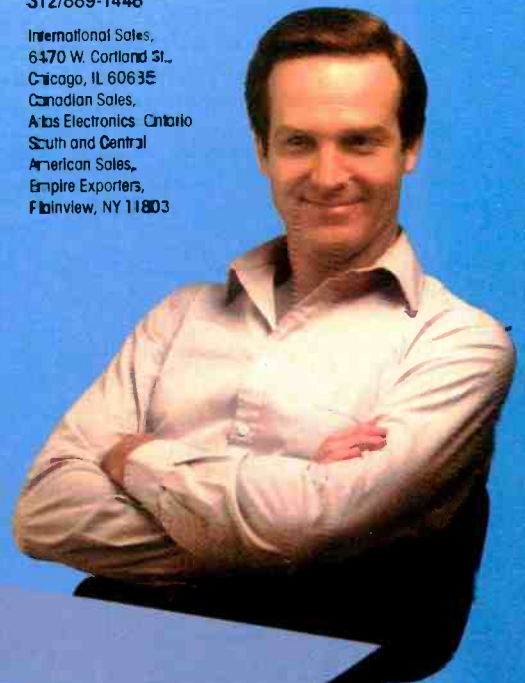

*B&K Precision  
model 560!*

Model 560 \$3500  
AK-560 Software \$495  
Circle (9) on Reply Card

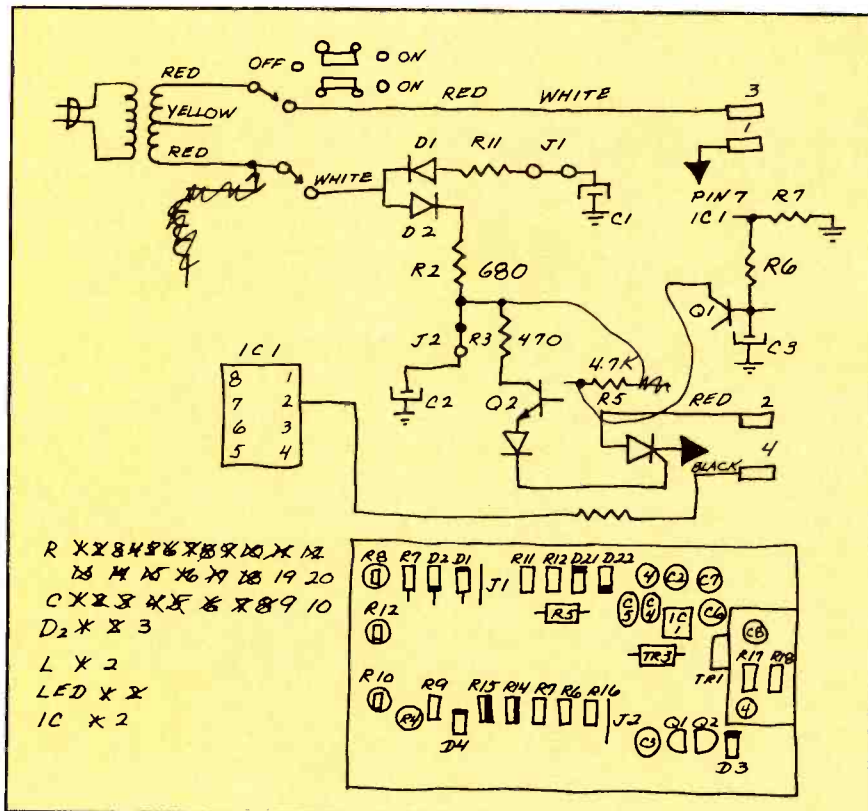

Figure 4. The first step in circuit tracing is to locate the  $V_{CC}$  and ground foils. The layout diagram and component numbers are also contained on this sheet.

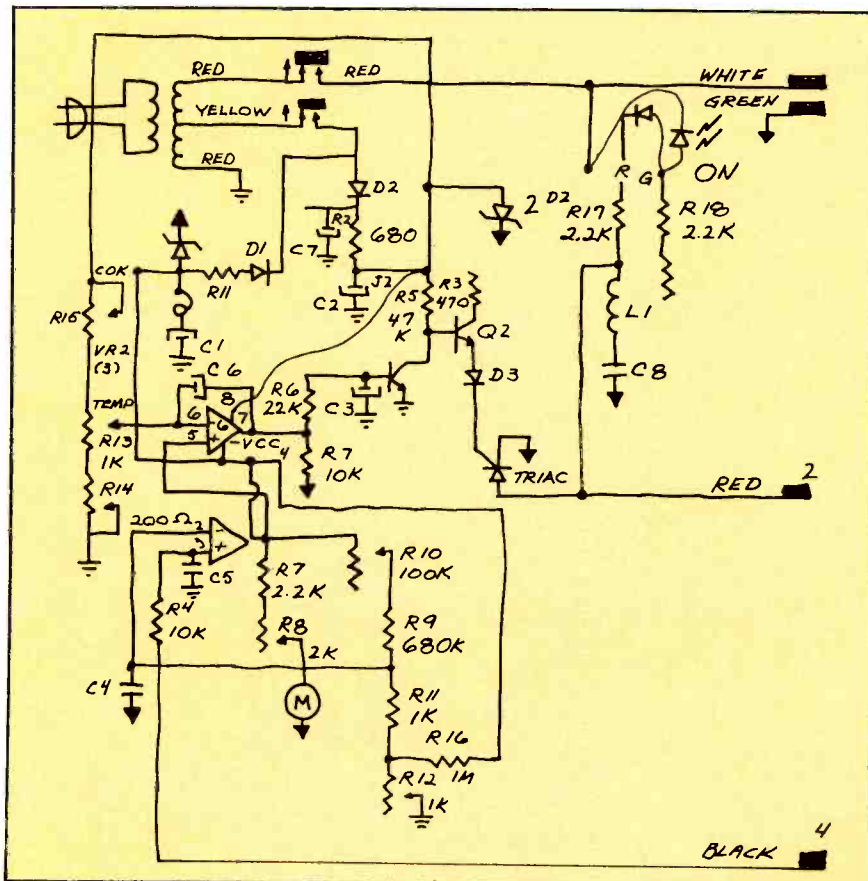

Figure 5. Because of changes and additions, the schematic should be redrawn and reorganized frequently.

groups and circle those areas on your component layout diagram. It establishes the grouping of components and the tracing range for each section of the device. If you find you have strayed from that area, it serves as a caution that you may have made a mistake.

If circuit identifiers are not provided, the location, structure and types of components also provide information as to their relationship and function. For example, high-frequency circuits frequently have coils exposed instead of shielded. Other high-frequency sections may have a shield over a group of components. Groups of shielded cans can identify a section, while the color coding on the adjustable slugs of cans can reveal their function. Outputs can be identified by transistor size or heat sinks. Audio sections may have interstage transformers or larger size circuit capacitors. There are a number of ways in which circuit areas can be identified. As you gain proficiency in this skill, you will find that it simplifies circuit tracing and is an asset during troubleshooting.

It is important to locate the trace or traces that provide  $V_{CC}$  to the various circuits on the board. It is also important that the common (ground) foil be identified. When these foils are located, color them with a magic marker or other coloring device. This is important — you will spend a lot of time relocating these foils if they aren't clearly identified. If you have more than one color marker, you might prefer to mark the  $V_{CC}$  and common foil a different color.  $V_{CC}$  may have series dropping resistors connected in the circuit. Make sure that you have the complete  $V_{CC}$  path identified and colored or otherwise identified.

### Standards

Review certain facts about ICs, types of amplifiers, methods of biasing and the general location of specific types of stages. It may help you recognize the form of the circuit you will be tracing and the method of stage interconnection. If you know what to expect, circuit tracing is much easier.

The location of certain circuit configurations and types of stages are fairly standardized because each has characteristics that make that type of circuit or method of biasing more effective at a given point or for a specific function. Some facts that relate to transistors are:

- An input stage will likely be a

# Cursors To Cure Measurement Curses.

Beckman Industrial  
Introduces The Series 9000.  
Speed, Accuracy, Performance  
And Value.

Presenting a new family of quality oscilloscopes with professional features. Choose from six models with frequency ranges of 20, 40 and 60MHz.



Model 9106,  
60MHz,  
3 Channel,  
Dual Sweep  
(A & B).

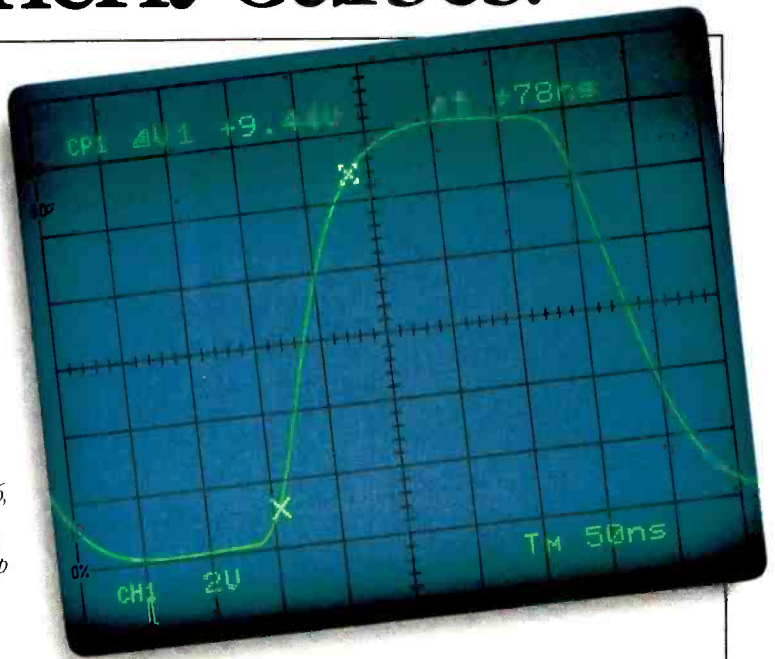

Independent cursors and  
on-screen readouts make  
waveform measurements  
fast and accurate.

Five of six models feature two independently-adjustable time bases. Built-in intensity modulation allows you to select a small section of a main waveform for closer examination. This feature is ideal for measuring pulse rise times or checking sync pulse amplitudes in composite video signals.

## Cursors And On-Screen Readouts.

Two sets of independent cursors are featured on Models 9202 and 9204. Simply position the cursors on the waveform and you instantly have accurate on-screen numeric readouts of amplitude, time, frequency, duty cycle and phase shift. A separate frequency counter is unnecessary. Interpolation is eliminated. You save time. Improve accuracy.

## Solid Design.

The Series 9000 features a low-profile cabinet, logically grouped controls, camera-mount CRT bezel and graticule illumination for waveform photography. Most models feature a three year warranty.

The Series 9000 Oscilloscope. Only from Beckman Industrial. Finally, the affordable cure for measurement curses.



Model 9204, 40MHz,  
On-Screen CRT Readout.



Model 9104, 40MHz,  
2 Channel, Dual Sweep (A & B).



Model 9022, 20MHz,  
2 Channel.

FEATURES	9106	9104	9204	9202	9102	9022
Max Frequency	60MHz	40MHz	40MHz	20MHz	20MHz	20MHz
Input Channels	3	2	2	2	2	2
Dual Sweep (A & B)	•	•	•	•	•	
CRT Readout			•	•		
Cursor Readout			•	•		
Switchable X1/REF/X10 Probes	2	2	2	2	2	2
Warranty	3 year	3 year	3 year	3 year	3 year	1 year
Price	\$1,290	\$950	\$1,095	\$865	\$700	\$550

## Beckman Industrial™

Beckman Industrial Corporation  
Instrumentation Products Division  
A Subsidiary of Emerson Electric Company  
3883 Ruffin Road, San Diego, CA 92123-1898  
(619) 495-3200 • FAX (619) 268-0172 • TLX 249031

common-emitter or common-base amplifier, with the common-base amplifier most often used in high-frequency input circuits.

- Circuits will usually use base, voltage-divider or collector-feedback bias. Less frequently, signal-derived bias (where the signal itself is the bias source) or a bias clamp, such as in a sync separator

circuit, are used.

- Common-collector (emitter-follower) amplifiers often precede output transistors and act as drivers or follow oscillators and act as buffers.

- Output amplifiers are frequently fabricated in a complementary symmetry configuration. An identical pair of output transistors usually indicates

Class-B push-pull operation.

- Transistor circuits following integrated circuits are usually driver and/or output amplifiers requiring more power than the IC can deliver. In these instances, the last two facts apply.

Circuit tracing integrated circuits can be difficult when manufacturers design chips to be used exclusively in their

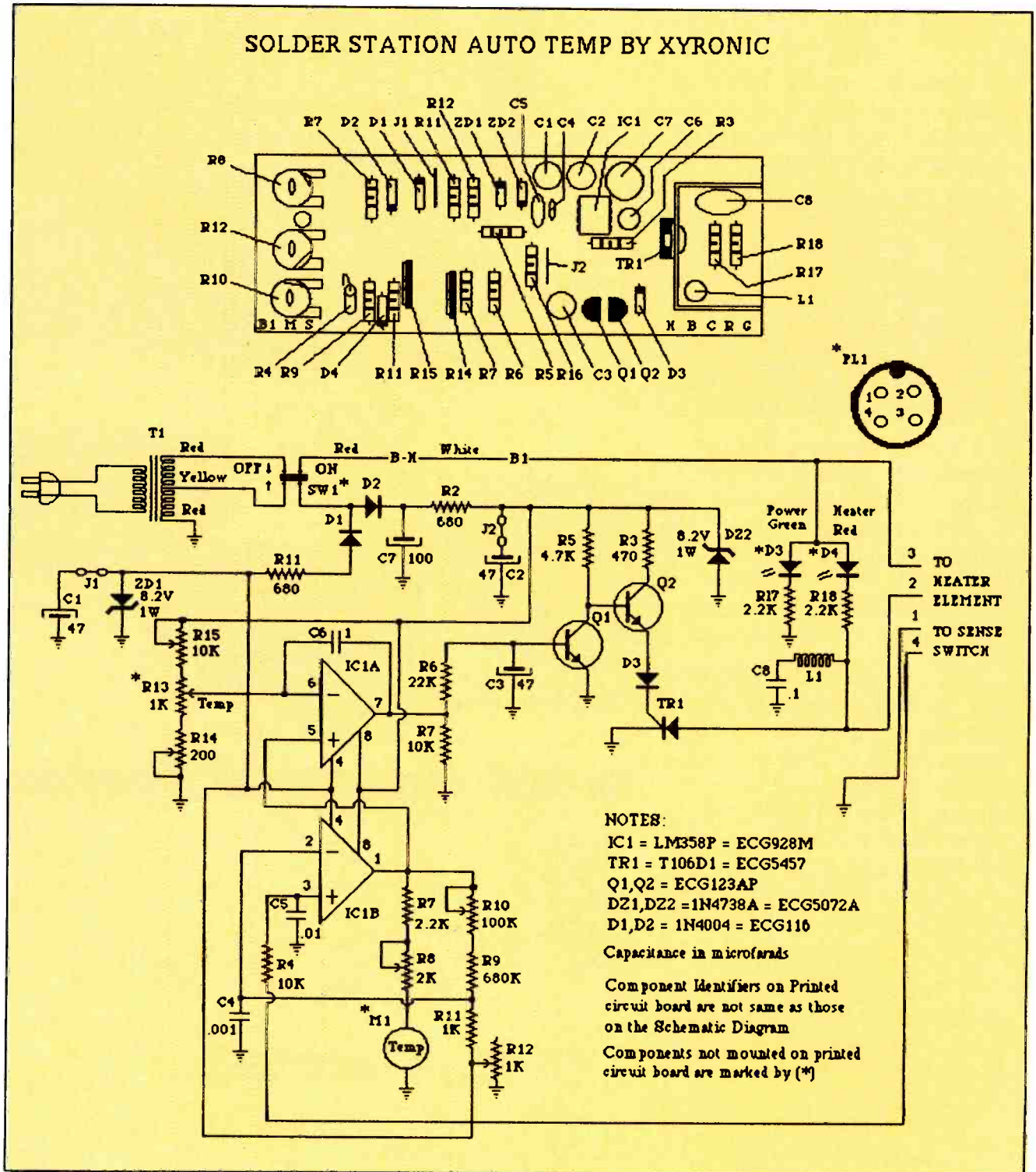

Figure 6. In the process of refining Figure 5, several inconsistencies were noted, which required additional tracing and clarification.

products. Products containing standard linear or digital ICs, such as the 7400 series, are less difficult to trace because the chips are well-documented. Standardization in the television industry is primarily by manufacturer and product line. The number of manufacturers and the diversification of ICs can make circuit tracing difficult. There are, however, common aspects that can be helpful when tracing. For example:

- Modern TV receivers generally employ a single IC for the IF section to include the detector stage and AGC.
- The luminance and chroma sections, including the color oscillator and demodulators, are often combined in a single IC.
- The vertical and horizontal sections are frequently combined in one chip employing a countdown circuit with vertical and horizontal driver outputs provided.
- Audio processing is usually included in a single chip.
- Scan-derived operating voltages are practically universal in state-of-the-art TV receivers. Input power supplies usually power the voltage regulator, horizontal output and start-up circuits of the horizontal processor.

### Circuit tracing

The first step in circuit tracing is to locate the  $V_{cc}$  and ground foils. This applies for either a partial or full trace. It is essential that these boundaries are located because they set the trace limits. Figure 4 shows this preliminary step in circuit tracing the soldering station. This initial diagram establishes that there are two power supplies in the device (negative and positive) and provides a starting point for developing the circuit.

The layout diagram and component numbers are also contained on this sheet. You will consolidate and reorganize information as the trace progresses. To save time and effort, draw both the circuit schematic and the component record and location diagram on the initial sheet. If the layout diagram is large, draw it on a separate sheet of paper so as not to interfere with drawing the schematic diagram of the traced circuit.

There are several incomplete traces shown on Figure 4. These points, shown as a pigtail, are indications that an additional component or components are connected to that point. When circuit tracing, you will often come to a branching point where several leads may

branch from the main foil. Be certain to show this junction on your diagram and show an extension for each arm leaving the junction. This is necessary to remind you to return and trace all foil leads from that point. If you fail to show a branching point and the number of branches, you might end up with omissions on your diagram and have difficulty determining the operation of the circuit.

Figure 4 also shows several corrections where the foil was followed incor-

rectly or components were not properly placed. Corrections should be made as they are noted without regard for the looks of the diagram. You will likely redraw and reorganize the drawing several times during the trace. Don't make too many corrections before redrawing the schematic. Transcribing and simplifying the schematic can be difficult if a number of scratch-outs, line crossovers or erasures are made. Errors are not unusual during circuit tracing and will be made by even an experi-

# Instrumentation. Cover to Cover.

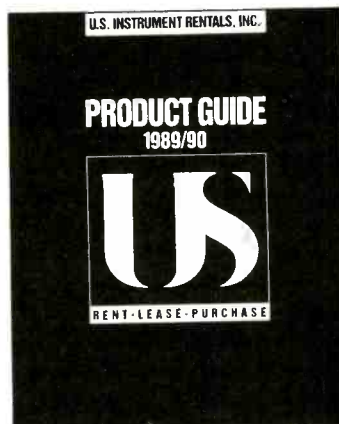

**800-824-2873**  
RENT-LEASE-PURCHASE

With the new 1989/90 Product Guide from U.S. Instrument Rentals that's exactly what you get. This hardbound guide is packed with over 5000 products from more than 170 major manufacturers. Browse through our comprehensive product sections—analyzers, counters, oscilloscopes, microprocessor development systems, computer products, power sources, generators, telecommunications products—and more!

The detailed product descriptions, product photos, and unbiased, thorough product comparison charts help speed your product decisions, and provide you with a valuable reference tool you'll come to rely on. We're sure you'll find this to be the most complete, authoritative guide to instrumentation available.

Call or write for your free copy, and let our 1989/90 Product Guide begin working for you.

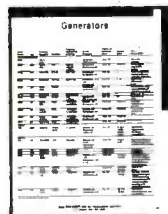

Product Specification Charts



Detailed Product Descriptions with Photos

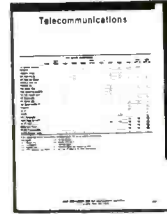

Unbiased Manufacturer's Comparison Charts

United States Instrument Rentals, Inc.



A U.S. Leasing Company  
2988 Campus Drive  
San Mateo, CA 94403  
800-824-2873

Circle (11) on Reply Card

June 1989 *Electronic Servicing & Technology* 19

enced individual.

To protect against errors, verify each foil connection. Make ohmmeter measurements when you are in doubt. You will quite often trace the circuit to a coil, transformer or through-board connection (grommet) and have difficulty locating the unseen connecting point. It may also be difficult to determine which

component is connected to the foil side of the board. Checking connections with an ohmmeter is the best method of verifying what you cannot see. Transformers, in particular, can be misleading. You expect that the input connections will be on one side of the transformer and the output connections on the other; however, this assumption is often not the

case. All transformer connections should be verified.

As you review Figure 4, the importance of understanding methods of biasing and types of stages should strike home. Quite often, what you have already traced will tell you what to expect, which simplifies the operation considerably because you can more

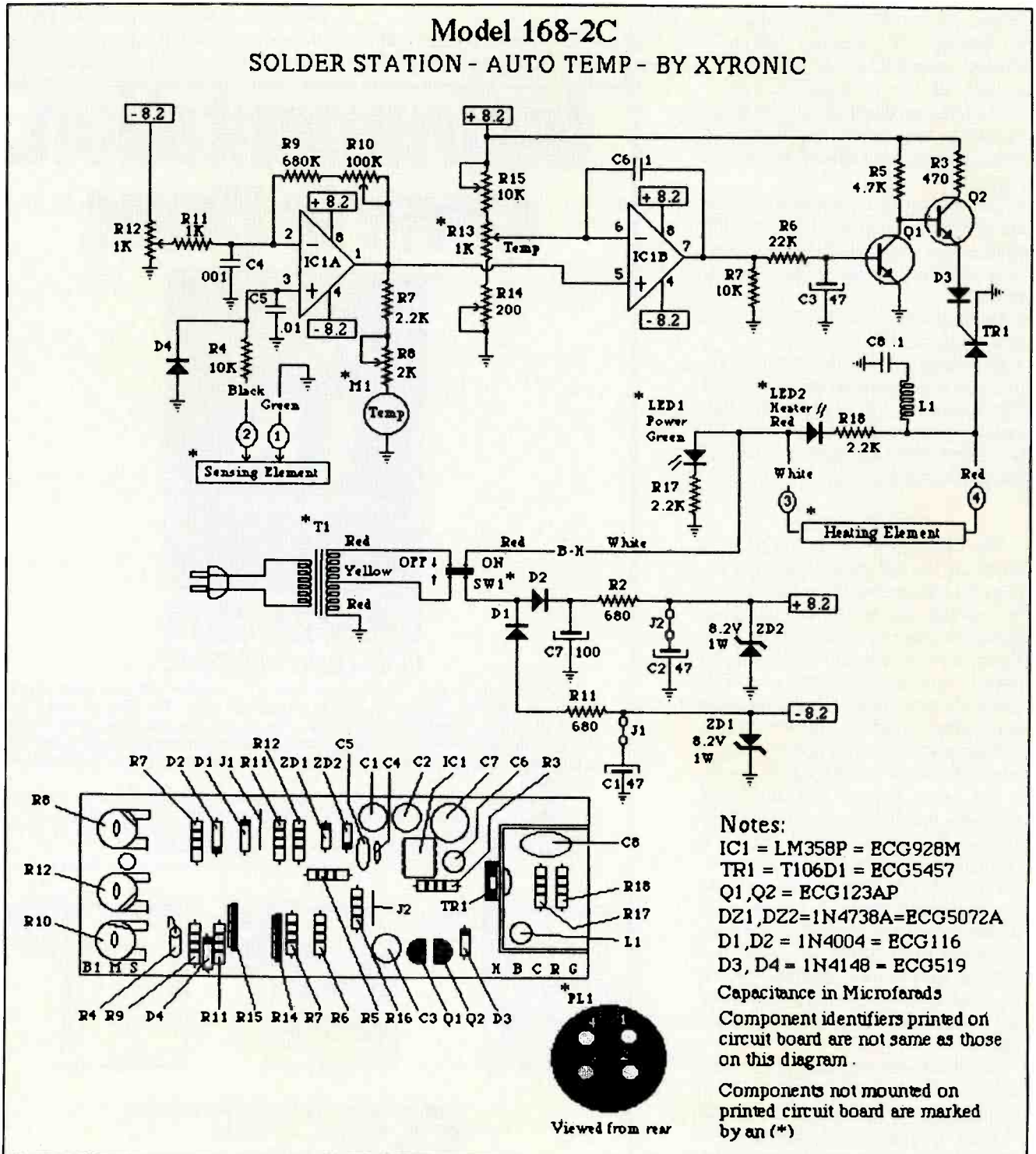

Figure 7. Although Figure 6 was accurate and reasonably well-organized, Figure 7 presented the same information in a simplified form. This drawing includes wire color, component identification, cross reference information, component location and plug connections.

easily tell if you are making an error. Drawing the circuits in a standard textbook form helps you recognize the circuit while it is being drawn and enables you to detect errors as you trace.

As your circuit is sketched, changes and additions to traces result in disorganization. Redrawing what you have sketched and reorganizing it so it presents an organized schematic should be accomplished at frequent intervals. Figure 4 was redrawn and is shown as Figure 5. Redrawing the diagram and reorganizing the information into a more acceptable form allows you time to study what you have accomplished. In this instance, it revealed that diodes DZ1 and DZ2 required additional tracing. The correction was made on Figure 5.

When drawing the schematic, do not neglect your component layout diagram. It is an important aspect of circuit tracing. As you label components on the layout diagram, your component layout tells you which components you have already traced and what is remaining. If the recommended preparations have been made, the component layout may provide additional important informa-

tion. The component numbers are an important item. If you neglect to strike out used numbers, you may find that they are duplicated, which can confuse you and require additional tracing and verification when the drawing is consolidated.

Figure 6, the completed diagram, is very similar to Figure 5 as it formalizes the trace. It was reproduced on a computer to provide schematic-like quality. Several items have been changed from what is shown on Figure 5. In the process of refining the drawing, several inconsistencies were noted, which required additional tracing and clarification.

Although Figure 6 was accurate and reasonably well-organized, I decided, after a little study, that it would be more understandable if it were simplified. Figure 7, the final drawing of the series, presents the information in a very understandable fashion. On this drawing, wire color, component identification, cross-reference information, component location and plug connections were included. This drawing lacks only voltage measurements around the active devices

to make it a fully functional service sheet. As indicated on the figure, this is the schematic diagram for the XYRONIC model 168-2C temperature-controlled solder station. I selected this item for circuit tracing because several had failed and I was unable to obtain a schematic diagram from my supplier.

It is very difficult to explain how to circuit-trace once the initial preparations have been made. Attempts to describe when and how to verify a connection, etc., is cumbersome and makes dull reading. The important points relating to circuit tracing have been explained and, if used, will ease the stress involved in this venture. The benefit derived from redrawing and refining the diagram frequently is illustrated by the number of corrections and changes detected during this process. The need for an adequate reference text is apparent and is accentuated by changes between Figures 5, 6 and 7. These, aside from the mechanical process of tracing and perseverance, are possibly the most important aspects of circuit tracing and are the key to your success in this venture.

**ES&T**

# TUCSON

August 7-12, 1989

## 1989 National Professional Electronics Convention and Professional Electronics Trade Show

- For Consumer Service Dealers and Technicians
- Management and Business Seminars
- Technical Seminars and Certification
- Meetings with Major Manufacturers' Reps
- Trade Show and Association Meetings
- Instructors Conference
- Sponsored by the National Electronics Sales & Service Dealers Assn. and the International Society of Certified Electronics Technicians
- Special room and transportation rates provided by Loews Ventana Canyon Resort, Tucson AZ



For more information, call or write to NPEC '89, 2708 West Berry Street, Fort Worth, TX 76109; (817) 921-9061.

Name \_\_\_\_\_  
 Address \_\_\_\_\_  
 City \_\_\_\_\_ State \_\_\_\_\_ Zip \_\_\_\_\_  
 Phone \_\_\_\_\_

## True Portability

... in the palm of your hand.

The SC04 Signal Computer has set new standards for advanced digital instrumentation.

- 20 MS/Sec Digital Storage Scope
- DVM with True RMS and Peak to Peak
- Digital Frequency Counter/Timer Meter
- Self-Calibrating for Unmatched Reliability
- Accuracy Readouts on all Meter Functions
- Auto Setup and Auto Zero for Easy Operation
- Recalls 10 Setups and 46 Waveforms, More on PC
- Centronics and RS232C with Full Control Software

**CREATEC**  
 SIGNAL COMPUTER  
 ©1989 Createc Signal Computer

Call Toll-Free 1-800-222-2688  
 3337 Kifer Rd. • Santa Clara, CA 95051

Circle (12) on Reply Card

# Test your electronics knowledge

By Sam Wilson, CET

1. The amount of bipolar transistor current in an amplifier circuit can be controlled by the amount of

- A.  $V_{EE}$ .
- B.  $R_E$ .
- C. base current.
- D. All of these choices are correct.

2. Two differential amplifiers are direct-coupled. Their combined voltage gain is

- A. the sum of the gains of each differential amplifier.
- B. the product of the gains of each differential amplifier.

3. When a differential amplifier is connected in a common-mode configuration, the output voltage *should* be

- A. maximum.
- B. 0V.

C. a negative voltage.

4. Another way of expressing bipolar transistor alpha ( $\alpha$ ) is

- A.  $h_{FE}$
- B.  $h_{FB}$
- C.  $h_{FC}$

5. Which of the following is another name for a 3-layer diode?

- A. Shockley diode
- B. tunnel diode
- C. hot carrier diode
- D. diac

6. Flicker noise is not present in

- A. field-effect transistors.
- B. bipolar transistors.
- C. vacuum tubes.
- D. None of these choices is correct.

7. Which terminal of the diode in Figure A is the cathode?

- A. The one marked with an X.

B. The one marked with a Y.

8. Figure B shows a Norton generator consisting of a constant-current generator ( $I_N$ ) and resistor ( $R_N$ ). The silicon diode has maximum ratings of 4V at 80mA. How much current will flow in the diode if it is connected across the circuit? Use the graph in Figure C to get your answer.

9. Refer to the circuit in Figure D. When the switch is closed, the voltage at point X will

- A. go to 0V.
- B. become more positive.
- C. become less positive.

10. Is the following statement correct? "An R-C differentiating circuit — such as the one in Figure E — cannot give an exact (differentiated) output for a given input."

Answers are on page 45.

Wilson is the electronics theory consultant for ES&T.

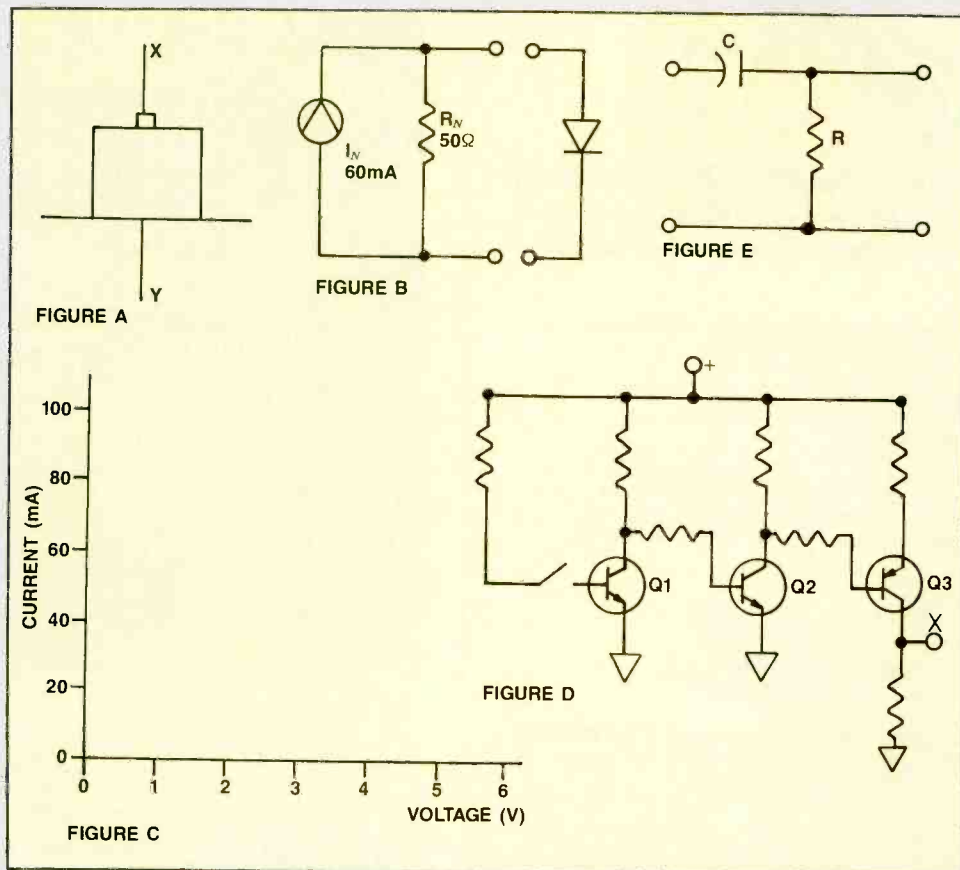



# The Wave of the Future...

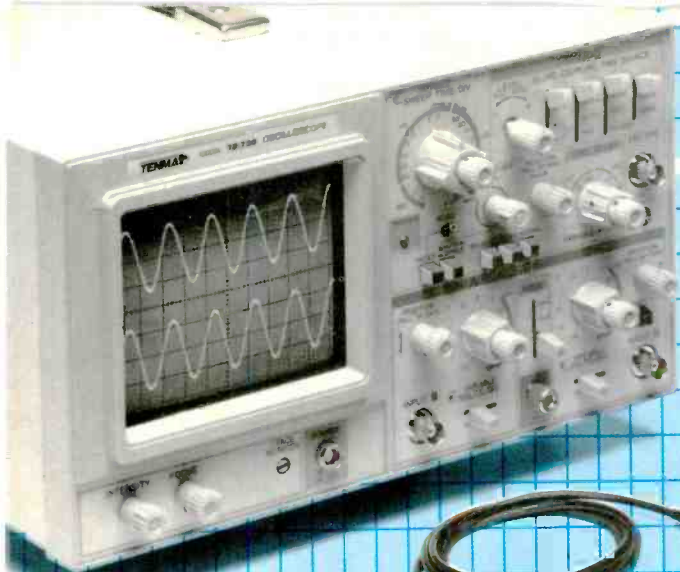

A.

B.

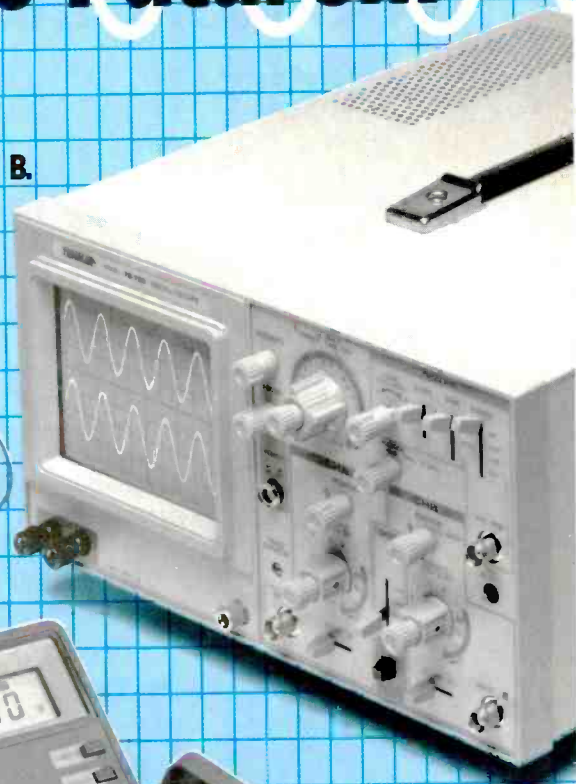

C.



D.



E.

F.



G.

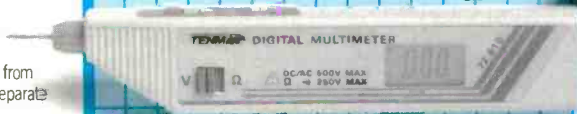

## TENMA and MCM Electronics

The field of electronics is always advancing and new technologies are constantly introduced in the products you service. Fortunately, one thing stays the same: Tenma quality and superior customer support from MCM. With top quality Tenma test equipment and superior sales and technical assistance from MCM, you can't go wrong.

### A. Tenma Dual Trace 35MHz Oscilloscope

The newly restyled Tenma 35MHz dual trace oscilloscope is designed to meet the complex demands of today's electronic industry. It is versatile enough for use in production, service and design and employs a metal-back post accelerated CRT for accurate reproduction of wide bandwidth signals. This model features a delayed triggering sweep, 5" high brightness CRT, and an internal graticule to eliminate parallax errors. Two probes included. Two year limited warranty. #72-730

### B. Tenma Dual Trace 20MHz Oscilloscope with Component Tester

Attractive contemporary styling and quality construction combine to make our most popular oscilloscope an even better value. Specifications include 5mV/civ. sensitivity and a frequency characteristic response with a smooth roll-off exceeding 20MHz. The component tester gives a visual display of the characteristics, value and condition of resistors, capacitors, inductors and diodes; in or out of circuit. Two probes included. Two year limited warranty. #72-720

### C. Tenma 60MHz Oscilloscope Probe Kit

High quality probe kit for use with any oscilloscope with up to a 60MHz bandwidth. 1x and 10x selectable attenuation with reference position. Fast rise time. 6" earth lead and IC clips. 90 day warranty. #72-530

### D. Tenma Autorange DMM

This DMM has a rotary dial for rapid selection of functions and automatically selects the proper range for the most accurate readings. Features a 3½ digit LCD display with data hold feature. For manual ranging, its autorange feature may be overridden. Audible continuity tester and switchable Lo/Hi power ohms. One year limited warranty. #72-560

### E. Protective Holster Case for DMM

High impact rubberized holster protects our #72-560 Autorange DMM from damage due to falls and it can be worn on the waist or shoulder with separate holster belt. #72-615

### F. Tenma Pocket DMM

A pocket size autorange DMM that is well suited for field work. Simply select function, and the meter automatically selects the proper range for the most accurate readings. The handy data hold feature saves the display reading after the meter is removed from circuit. Diode tester and audible continuity tester. One year limited warranty. #72-600

### G. Tenma Probe Style DMM

Probe style DMM for convenient one-hand operation. The meter automatically selects the proper range for the most accurate reading. 3½ digit LCD display with data hold to save reading after the meter is removed from circuit. Audible continuity tester. One year limited warranty. #72-610

To receive more information on these and other Tenma products call **1-800-543-4330** for a **FREE** subscription to our catalogs or write...



**MCM ELECTRONICS**

650 CONGRESS PARK DR.  
CENTERVILLE, OH 45459-4072

A PREMIER Company

Source No. ES-46

Circle (13) on Reply Card

# Servicing the RCA CTC107 color TV – Part II

By Homer L. Davidson

Servicing RCA CTC107 13-inch portable color TVs seldom presents any unusual problems. The design and layout are efficient, squeezing many components into small spaces. That's not new, however; crowded components are the rule, not the exception, for all late-model color TV receivers. Fortunately, some problems with servicing the small chassis are offset by the addi-

Last month, we introduced the RCA CTC107 and looked at some specific trouble symptoms. This month, we'll look at some specific problems that can be caused by a defective U701, the luminance/chrominance IC.

## Luminance/chrominance U<sub>701</sub>

In addition to luminance problems such as flashing or distorted picture, ex-

have chroma signals. After you locate the IC pins that have incorrect or missing chroma signals, accurately measure the dc voltage at each of these pins. These are the pins that need additional testing.

Measure the U<sub>701</sub> B+ supply at terminal 23. It should test about +10.5V. Readings higher than +11V could indicate an open U<sub>701</sub>. Unfortunately, the precise B+ voltage is not helpful when you suspect moderate internal leakage. I have encountered several CTC107s in which the B+ measured no more than 0.5V low, but replacing U<sub>701</sub> solved the problem and restored normal color reception. Use exact part 146858 for replacement.

Assuming you have determined that U<sub>701</sub> is defective, the next step is replacement, but there are several potential problems. **WARNING:** This IC can be installed backwards, perhaps damaging the replacement IC or the circuit. If U<sub>701</sub> is installed backwards, the next steps include the delicate and nerve-wracking jobs of desoldering all 28 pins, turning around the IC, plugging it into holes correctly and soldering the pins skillfully without shorts.

The following is a brief description of some important things to notice and perform before and during the U<sub>701</sub> installation. Before the original IC701 is removed, make a rough drawing that shows the locations of important components, including U<sub>701</sub>. Mark the U<sub>701</sub> pin 1 corner before the IC is desoldered. Pin 1 is (and must be after the reinstallation) in the corner nearest C<sub>713</sub> and C<sub>708</sub>. Or choose your own landmark. When pin 1 is in the correct hole, all other pins will line up correctly.

Soldering these integrated circuits requires more preparation and care than ordinary soldering does. ICs of this type can be damaged by excessive heat or excessive voltage. Protecting ICs is com-

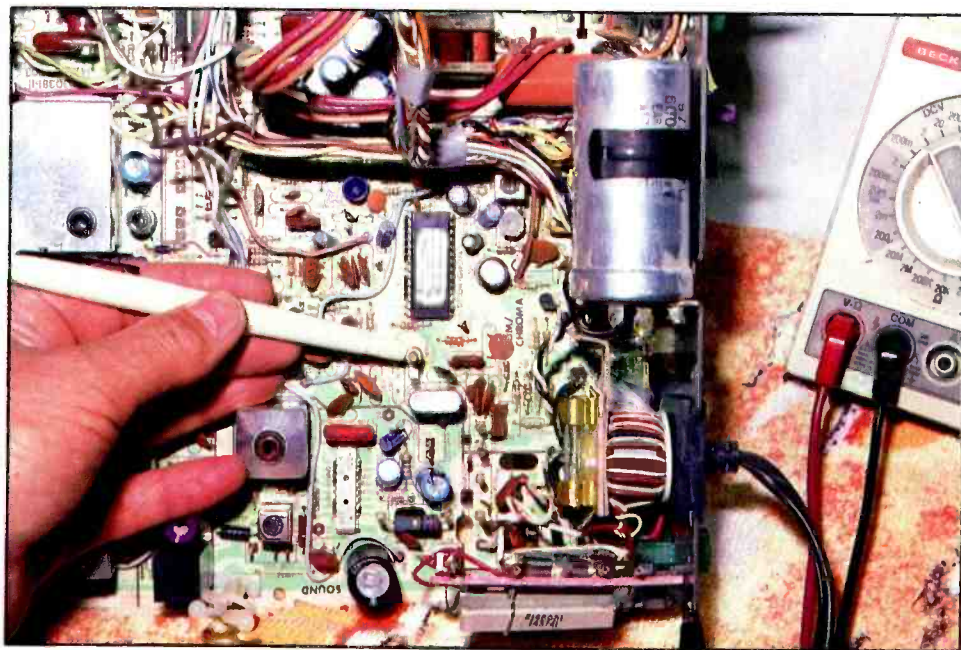

A pen points to trimmer capacitor C818 of the 3.58MHz oscillator circuit. This capacitor has a reputation for causing intermittent color problems. Light tapping or prodding with an insulated rod on C818 sometimes triggers the problem into starting or stopping. If there are any reasons to doubt C818, replace it. Remember that the replacement must be adjusted to bring the chroma into lock (eliminate stripes in the color areas of the picture).

tional hours of engineering that RCA apparently has applied to these small machines. The large number of test points, for example, help make troubleshooting much easier.

Davidson is the TV servicing consultant for ES&T.

cessive brightness, retrace lines or shutdown malfunctions, integrated circuit U<sub>701</sub> also can produce many chroma problems.

To determine if U<sub>701</sub> is defective or if the chroma problem is elsewhere, carefully scope all U<sub>701</sub> pins that should

plex because some dangers come from unsuspected sources such as heat from desoldering or soldering. Other failures occur from higher voltages, especially static discharges. There are many rules for guarding ICs against failures from heat and voltage, but the subject requires several pages for a full explanation. Therefore, we are describing the major safeguards and then listing a recently published source for more detail.

For soldering, the first requirement is an appropriate soldering iron, with a rating between 25W and 35W, that has a small chisel tip. However, do not use a smaller iron that is only warm; such an iron requires much longer to melt the solder properly, and a longer application of heat is more likely to heat the IC body excessively.

To prevent static voltage damage to the IC that is being soldered, use only a soldering iron with a grounded tip. Also, wear a grounded wrist-strap when soldering or working around ICs.

Excess solder must be removed from each terminal/pin of the old IC; solder wick usually is best for this use. Do not use a blue-colored plastic solder sucker. Some generate as much as 20kV of static electricity when operating! Use a solder sucker (if you like that method) that is static-free.

The IC terminal pins of this CTC107 model are bent over and soldered to the circuit board. Therefore, each pin will require straightening before the old IC is removed. With the soldering iron, remove enough solder to permit each pin to be straightened, then remove all possible solder from both sides of the pin. This straightening can be performed with a knife blade, a screwdriver blade, a special solder-removal tool, or with the soldering iron's tip (if it has the correct shape). During all this activity, use care to not damage the circuit-board wiring. If any wiring is damaged, repair

the problems immediately before you become distracted by other details and forget to do it. Solder bridges can be removed with the iron and solder wick.

After the terminals have all been desoldered and you have noted again the location of pin 1, it is time to remove the old IC and deposit it with terminals down against the metal on a piece of sheet aluminum or conductive foam, which you should already have prepared.

Before you remove the new IC from its protective package, touch the conductive foam or aluminum foil of the IC package with one hand and at the same time touch the receiver chassis with the other hand (this equalizes the static voltages). Insert IC U<sub>701</sub>, carefully aligning it with the correct location of terminal 1. After all pins have been inserted sufficiently, bend over the terminal tips (as the tips were before desoldering) and solder each rapidly and carefully. Clean all debris from these connections and the surrounding areas with a short-bristled, metal-handled brush. Recheck each connection for sufficient strength and the appearance of a smooth-flowing joint.

Do not use freon-propellant sprays on any part of a chassis that contains ICs. Some freon sprays can generate up to 5kV of static voltage. If you use a cleaning spray on the newly soldered IC connections, make sure it is an anti-static type.

Space does not allow additional explanations of the largely unknown static voltages, the problems and the solutions. Our October 1988 issue has a full-length article (beginning on page 42) titled "Locating ESD Hazards." The acronym ESD is taken from electrostatic discharge, which is lightning in miniature. I suggest you read the article carefully. Among other things, it might explain why so many replacement

ICs have not operated correctly after installation!

#### **Loss of color/weak color**

When absence of color is the symptom, begin by scoping the chroma test points, trying to locate the general area of the defect. Most chroma problems are associated with IC U<sub>701</sub>. There are only two points where chroma (without demodulation) can be scoped at U<sub>701</sub>. The first official test point is TP801 at U<sub>701</sub> pin 3. The other is a pair of test points at pins 1 and 17: The signal exits at pin 1, travels through a few resistors and capacitors, then enters U<sub>701</sub> again

#### **Sometimes a gentle prodding with an insulated rod can start the defect or stop it temporarily, thus locating the general area of the problem. This is a better solution than wholesale resoldering.**

at pin 17. Pin 17 should have a strong chroma signal. If it has zero signal but TP801 has a normal 0.2V<sub>PP</sub>, the primary defect is in U<sub>701</sub>, its dc voltages, or any of several critical components around it.

Y<sub>801</sub>, the 3.58MHz crystal, has a reputation for failures. Therefore, if you suspect it, replace it; that's the only certain test. Anytime a new crystal is installed, use a non-metallic screwdriver to adjust C<sub>818</sub> as needed to eliminate stripes in the colors (that is, bringing the chroma into lock).

If the color has not been restored by now, measure the dc voltages at U<sub>701</sub> terminals 11, 12 and 13, comparing them against the schematic. (See Figure 1.)

Measure the resistance of 1,000Ω R<sub>813</sub> and L<sub>804</sub>. Replace any that test out of tolerance.

Of course, U<sub>701</sub> causes many of the color problems. Before replacing this IC, however, visually inspect all terminal connections and the surrounding soldered joints. Check the soldered junction where 1μF C<sub>806</sub> and 3.3MΩ R<sub>803</sub> are connected together. Replace C<sub>806</sub> if it appears to be faulty (a slightly higher capacitance is permissible) and make certain the joint is good. One possible cure for a no-color symptom is to securely solder the junction of 0.001μF C<sub>804</sub> and 330kΩ R<sub>817</sub>. Resolder any terminal of U<sub>701</sub> that has corrosion, small cracks, loose solder or grainy, brittle-looking solder.

If the chroma waveforms at pins 3 and 17 of U<sub>701</sub> are about normal, but pins 20, 21 and 22 have no demodulated chroma, it is likely that U<sub>701</sub> is defective. However, measure the supply voltage at terminal 23, expecting the

normal +10.5V. If this supply voltage is very low, test for a leaky U<sub>701</sub> or a defective power source. Common component failures in the power source include CR<sub>302</sub>, CR<sub>706</sub> and Q<sub>302</sub>.

In several sets I have encountered, L<sub>805</sub> coils had become open in service (see Figure 2), causing weak color. L<sub>805</sub> and C<sub>813</sub> are in series between TP807 at pin 15 and the "I" demodulator at pin 18. Additional phase-changing components between pin 18 and pin 19 shift the phase for the "Q" demodulator. Therefore, an open L<sub>805</sub> removes almost all the 3.58MHz carrier from both demodulators, permitting only weak chroma.

Scope pin 7 of U<sub>701</sub> for the sandcastle waveform of 10V<sub>PP</sub>. If the waveform is missing or weak, the chroma will be missing or weak. Test Q<sub>801</sub> in-circuit. Measure the resistance of L<sub>807</sub>, and use the DMM's special diode test on CR<sub>702</sub>. Remember that the sandcastle waveform is composed of positive sync,

horizontal-blanking and vertical-blanking pulses. If any one is missing, trace that path back toward the source. An open should be found before the source is reached.

In another case, another component supplying pin 7 caused weak video and a dim raster. Therefore, the pin 7 sandcastle waveform can affect both chroma and luminance. This U<sub>701</sub> pin 7 signal is indispensable.

### Intermittent color

Intermittent color can be caused by a corroded IC terminal or almost any chroma-circuit connection that has tiny cracks in the solder. Sometimes a gentle prodding with an insulated rod can start the defect or stop it temporarily, thus locating the general area of the problem. This is a better solution than wholesale resoldering without a known target, which is a last-ditch alternative.

In several cases, trimmer capacitor C<sub>818</sub> was found to have caused either in-

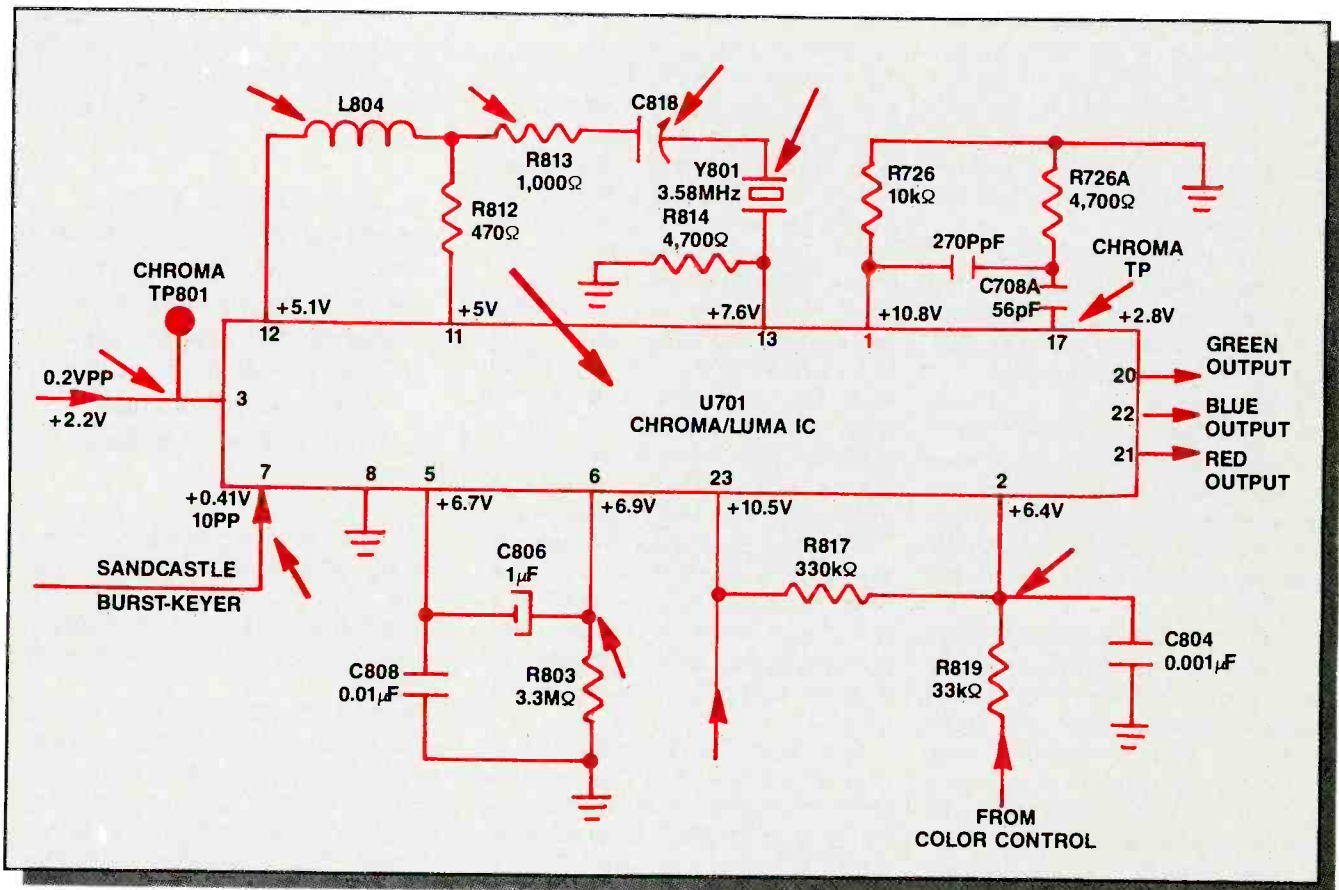

**Figure 1.** Components marked by arrows have past histories of causing loss of color; check them carefully or replace them. Some troublemakers include: IC U<sub>701</sub>, L<sub>804</sub>, R<sub>813</sub>, C<sub>818</sub> and crystal Y<sub>801</sub>. Pin 3 is color input and testpoint. Pin 17 is the final color input pin, but not an official testpoint. It is the last place the chroma signal comes into U<sub>701</sub> before demodulation. Pin 7 is the input pin for the sandcastle waveform. Neither luminance nor chrominance goes through U<sub>701</sub> without the proper waveform at pin 7. When C<sub>806</sub> is being replaced at pin 6, check and repair the soldered joint where the leads of C<sub>806</sub> and R<sub>803</sub> join. Also, at pin 2, repair or resolder the joint where R<sub>817</sub> and C<sub>804</sub> are connected.

intermittent color or colors erratically appearing in bars or stripes on the screen. Another troublemaker is  $Y_{801}$ , the 3.58MHz color crystal. When you are in doubt about  $Y_{801}$ , replace it.

Also, remember that  $U_{701}$  defects can produce incorrect color hues, loss of one or more chroma output signals, or intermittent color.

If one of the three colors is intermittent, scope the affected color's  $U_{701}$  pin. If any of the demodulated chroma is intermittent at pin 20, pin 21 or pin 22, the chances are very high that  $U_{701}$  is defective. However, if red is intermittent in the raster but not at pin 21, the problem is further downstream in the bias transistor or the driver (color-output) transistor for that color.

### Chroma or color?

At this point, it might be helpful to differentiate between circuit color and raster color during troubleshooting.

Often the words chroma and color are used interchangeably, but they are not always the same in color TV receivers. The only visible color in a color receiver is on the faceplate of the picture tube.

Before they reach the picture tube, the signals that will paint colors on the black-and-white screen are merely electronic signals, called chroma, chrominance or demodulated chroma. The signals sent to the picture tube cathodes are correctly called chroma/video.

This is not a course in color TV fundamentals, but a reminder that we should become somewhat more careful about the names we apply to these signals. Otherwise, it is difficult to understand if the word "color" refers to an electronic signal or a visible color on the picture-tube face. This is very important when the subject is raster colors vs. circuit chroma signals.

### Green missing

When a CTC107 color receiver has a picture with green missing, there are three areas that might be the problem:

- the chrominance signal for green might be missing.
- the green bias and green output transistors might be defective.
- the picture tube might be defective.

CTC107 chrominance circuits are vastly different from those in older models. For example, most older color receivers had -Y chroma signals at the three CRT grids with Y (luminance)

signals delivered to the three CRT cathodes. Thus, matrixing of chroma and luminance signals occurred inside the CRT. But in the CTC107, demodulated chroma and luminance signals are matrixed together inside  $U_{701}$ . Therefore, only complete chroma/video signals come from  $U_{701}$  pins 20, 21 and 22. The point of this old/new comparison is to show the changes in trouble symptoms and the necessary changes in servicing pro-

cedures. In some older color receivers, one chroma signal (such as R-Y) can be lost without causing any large effect on the other two chroma signals or the B&W raster. Not so with the CTC107. Because the B&W video and the demodulated-chroma signals are matrixed, anything beyond pin 20 that eliminates one also removes the other. For example, loss of pin 20 video leaves a magenta raster, and the color is very poor because the accompanying loss of



Shown here:  
Model SP100 \$43.  
Switchable 1X-10X

## TPI Probes Last Longer, Cost Less

Unique flexible cable and superior strain relief give longer life and easier, more comfortable handling

Order from these distributors:

- ACTIVE
- ALLAN CRAWFORD ASSOC.
- ALLIED ELECTRONICS
- BCS ELECTRONICS
- CALCOTRON
- CHELSEA ELECTRONICS
- CMI METERMASTER
- CONTACT EAST
- EIL INSTRUMENTS
- ELECTRA TEST
- ELECTRONIC PARTS CO.
- ELECTROTEX
- FAIRMONT
- JENSEN TOOLS
- JOSEPH ELECTRONICS
- MARSHALL
- MC MASTER-CARR
- OLIVE ELECTRONICS
- RADAR ELECTRIC CO.
- RS ELECTRONICS
- SOUTHEASTERN ELECTRONICS
- SPECIALIZED PRODUCTS CO.
- TECHNI-TOOL
- WESTCON INC.
- WM. B. ALLEN

**TEST  
PROBES, INC.**

**TPI**

9178 Brown Deer Road, San Diego, CA 92121  
Call Toll Free for information and free catalog:  
1-800-368-5719  
1-800-643-8382 in CA

Circle (14) on Reply Card

demodulated chroma also has removed all green from the chroma colors in the picture.

In the list of three possible causes of missing green at the beginning of this section, the first possibility was concerned with pin 20 and whether it had a green chroma/video signal. In one

case, the chroma/video signal for green was present according to the scope waveform.

The second possible area of missing green contains the green bias and output transistors. Three of these, the color-output power transistors, are mounted on the CRT socket board. You can con-

veniently measure their collector voltages at the heat sink of each transistor.

A very helpful short cut in analysis begins with measuring all three heat sinks and the boosted B+ voltage that supplies these transistors. Write down these four voltages for analysis. The three collector/heat sink voltages in a normal receiver usually will measure within perhaps 10V of each other at around +160V. (However, these voltages change with color "temperature" adjustments.) If two are within tolerance and one is about +193V (the same as the boosted B+), the one with +193V is not drawing current, and its color hue will be blacked from the raster.

If all three heat sinks have about the same low voltage, suspect a failure in the +193V boosted voltage source. R<sub>125</sub> (4.7Ω) might have increased in resistance, or 30μF C<sub>117</sub> could have become open or very leaky.

In my experience, I have found a few small bias transistors that have failed in normal service, but I've seen far more of the larger power-type color output transistors that have become defective. For green color, Q<sub>705</sub> is the bias transistor and Q<sub>502</sub> (Q<sub>2</sub>) is the color output. (See Figure 3.)

When a CTC107 has had a normal screen color and suddenly develops a dominant tint over the entire screen, test for leakage in a color output transistor, and replace any defective ones. Measure the 10kΩ collector resistors of the three color output transistors. For Q<sub>2</sub> green, the resistor is R<sub>2</sub>; for Q<sub>3</sub> blue, the resistor is R<sub>3</sub>; for Q<sub>1</sub> red, the resistor is R<sub>1</sub>. Replace any resistors that measure out-of-tolerance or show signs of having been overheated.

Perhaps the least likely area for losing color is the CRT (number 3 on the loss-of-green list). However, some picture tube defects can produce visually weak or intermittent color. Check the picture tube with a good CRT tester if you have one available. Include tests for gas, leakages, opens and cathode emission for each gun. If the CRT test results are normal but the color remains erratic, examine the CRT socket for any evidence of an intermittent connection. Also, measure all dc voltages at the CRT socket (except the focus voltage, of course) when the raster tint is normal and then again when green is missing. If none of the voltages (particularly the CRT cathode voltages) change when the

*Continued on page 41.*

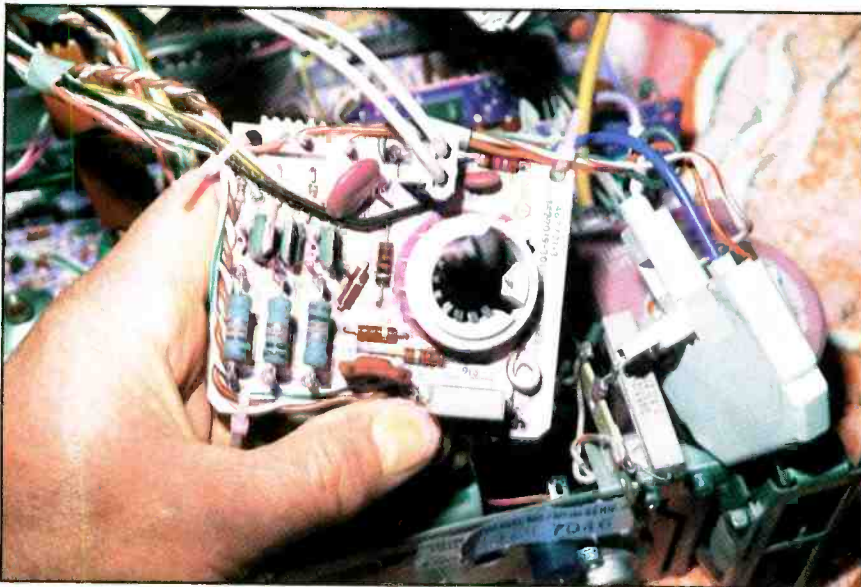

With the three large transistors mounted side by side on the CRT circuit board, it is easy to measure each collector voltage (and thus the corresponding CRT cathode) because this TO-220 type of power transistor has a small heat sink connected internally to the collector.

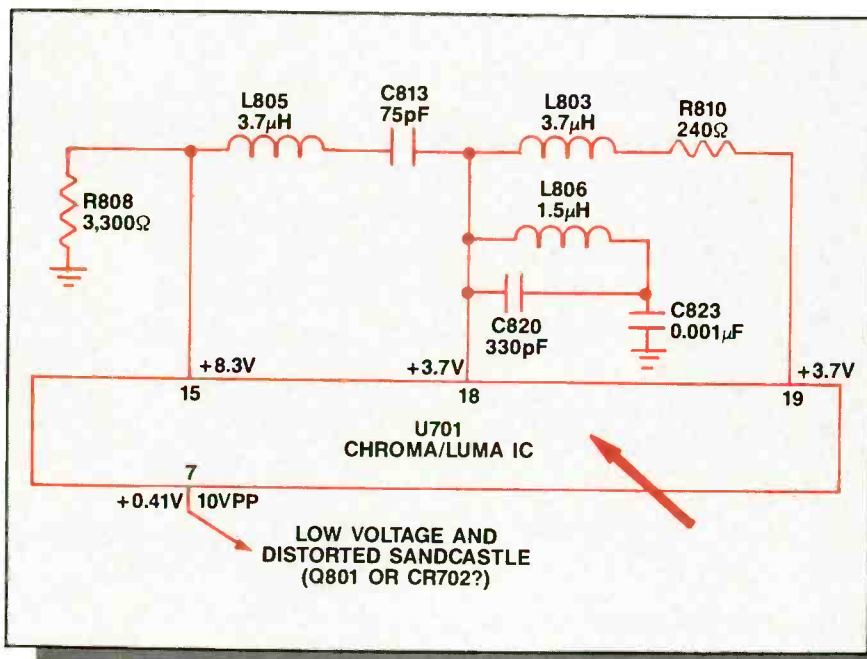
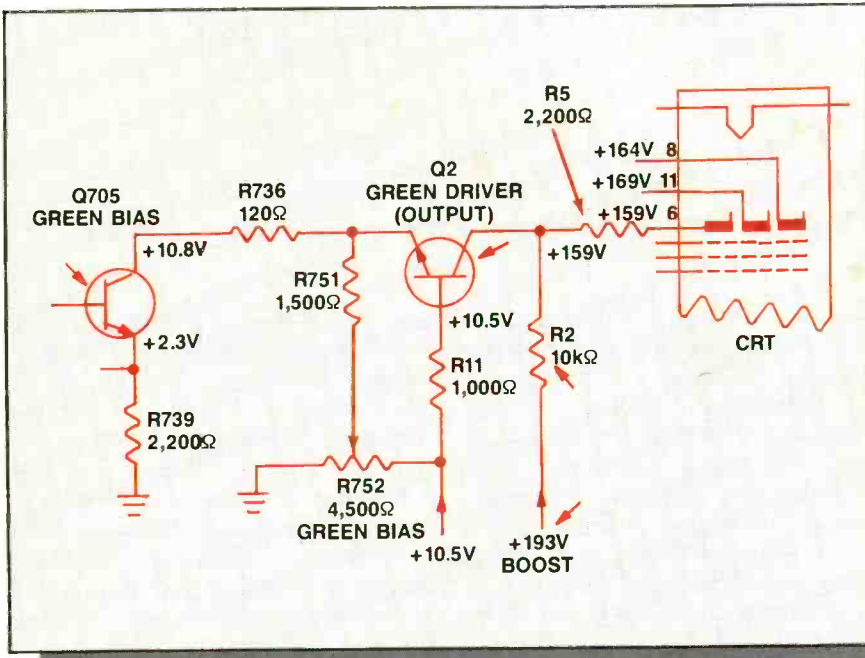

Figure 2. Several L805 coils are known to have opened, causing weak color. Other coils, such as L803, can open, but the reduction of color level is not as great as with L805. The sandcastle waveform at pin 7 is very important. Weaker amplitude or distortion of the sandcastle waveform can cause weak color. A total loss of the sandcastle waveform blocks both chroma and video. However, if the sandcastle waveform is good, nothing else is defective and U701 has the correct +10.5V at pin 23, perhaps U701 is causing the weak color and should be replaced.



**Figure 3.** When the picture has a total loss of green, test those transistors and components pointed out by arrows. (Also, several of these can cause the picture to be excessively green.) Remember to test the cathode voltages of the three CRT guns (testing the three driver/output transistor collectors is a convenient way). When the screen color-temperature adjustments have been made carefully, these three voltages usually will be within 10V to 20V of each other. Any larger voltage difference indicates a defect somewhere.

green disappears, the chances are high that the CRT is defective.

In a perfect world, our test results would show definitely that the CRT is or is not defective. We seldom are that fortunate, however, and we are left with the serious decision of replacing the expensive color CRT based on negative proof: nothing else is wrong.

Scoping waveforms is the most effective method of locating defective stages in video and chroma circuits. Next, measure voltages and resistances in the suspected stage to pinpoint the source of the problem.

### Conclusion

Many functions are performed in the CTC107 by U<sub>701</sub>, the luminance/chrominance processor IC. Therefore, U<sub>701</sub> can produce a large variety of video and color problems when it has a defect. Before you replace U<sub>701</sub>, however, be certain that no connecting components are causing the malfunction, and that the IC has its normal B+ supply.

Whenever possible, replace all ICs and transistors with original brand components.

**ES&T**

WATCH FOR

BUSINESS CORNER

**ELECTRONIC**  
Servicing & Technology

This exclusive monthly column will show you how to run your service operation more efficiently and profitably.

You'll learn about

- building customer satisfaction
- writing service contracts
- marketing your services
- hiring technicians.

## Presenting an affordable Light Box System.

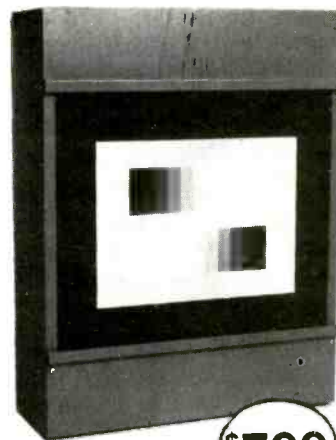

**\$799**

The method most manufacturers recommend

Model TR100 CB  
Camera Light Box  
with (2) transparencies

- (2) 3200° Kelvin Lamps (meets mfr. spec.)
- 1-year conditional guarantee
- Transparencies mounted in acrylic with optical scratch-resistant surface
- 11-step gray scale transparency
- 7-Bar color transparency
- All orders are shipped within 72 hours, U.P.S.

**NUTRONIX** (313) 939-2740



P.O. Box 77103 • Sterling Hts., MI 48077



Circle (20) on Reply Card

# This is an analog scope?

Analog is analog and digital is digital, right? Well, you might be surprised to find that your *analog* scope is hiding a lot of digital circuitry under its cover.

Measuring repetitive waveforms used to mean setting up the front-panel, counting graticule divisions and multiplying by scale factors. Most servicers know that modern scopes have made this job a lot easier, but some might be surprised to find out that digital scopes aren't the only innovation. Many of today's sophisticated analog oscilloscopes also greatly simplify this procedure.

## Pushing the limits of analog

On certain analog oscilloscopes, if you want to measure a repetitive waveform, you merely attach the scope's probe to a test point and press the MEASURE button. Then select the desired measurements from an on-screen menu. (See Figure 1.) The scope automatically does the rest.

Adapted from a paper published by Tektronix.

From the measure menu selection, the scope automatically sets up a measurement display of the probed waveform. Then it automatically determines values for the selected measurements and displays numerical results along with the waveform. Peak, peak-to-peak, average dc, frequency, period, widths, duty factors, rise and fall times, and general time A→B measurements can be made automatically without requiring the user to count a division or do a scale-factor multiplication.

This new push-button measurement capability promises to simplify and speed up day-to-day measurements in a wide range of applications. But it does raise a natural question: Without waveform digitizing, how can an analog scope do automatic waveform measurements?

The answer dispels a common misunderstanding about modern analog

scopes: that they are completely analog tools. Modern, sophisticated oscilloscopes are almost entirely digital instruments. The input channels, the sweeps and the triggers in today's advanced analog scopes are all microprocessor-controlled. That internal, digital-processing capability, along with precision ramps and triggering control, provides the basis for the new automatic measurement capability.

## Triggering and timing are the keys

To make any measurement on any waveform, some reference points need to be established. Digital storage oscilloscopes (DSOs) approach this by digitizing and storing the waveform as closely spaced sample points. Any stored point can be selected as a time or voltage reference. Measurements are then extracted from the stored array of digitized waveform points by common numerical analysis methods. On some DSOs, the measurements can be done automatically with push buttons and built-in processing. More commonly, however, the measurements must be made with manually placed cursors or through external analysis with an interfaced computer.

Because analog scopes don't digitize and store waveforms, they approach automatic measurements differently. Rather than using stored waveform points, they must look directly at the analog waveform to determine reference and measurement points.

Some modern analog scopes look directly at waveforms via their precision triggering circuits and sweep ramps. To understand the basic concept, consider the process of measuring the period and frequency of a sine wave. (See Figure 2.)

The first key to determining period in Figure 2 is the scope's ability to measure time from established reference points. The initial trigger point on the waveform is one established point. It starts the horizontal sweep ramp. Assuming that this analog ramp is accurately time-calibrated, any given point on the ramp corresponds to a specific time on the

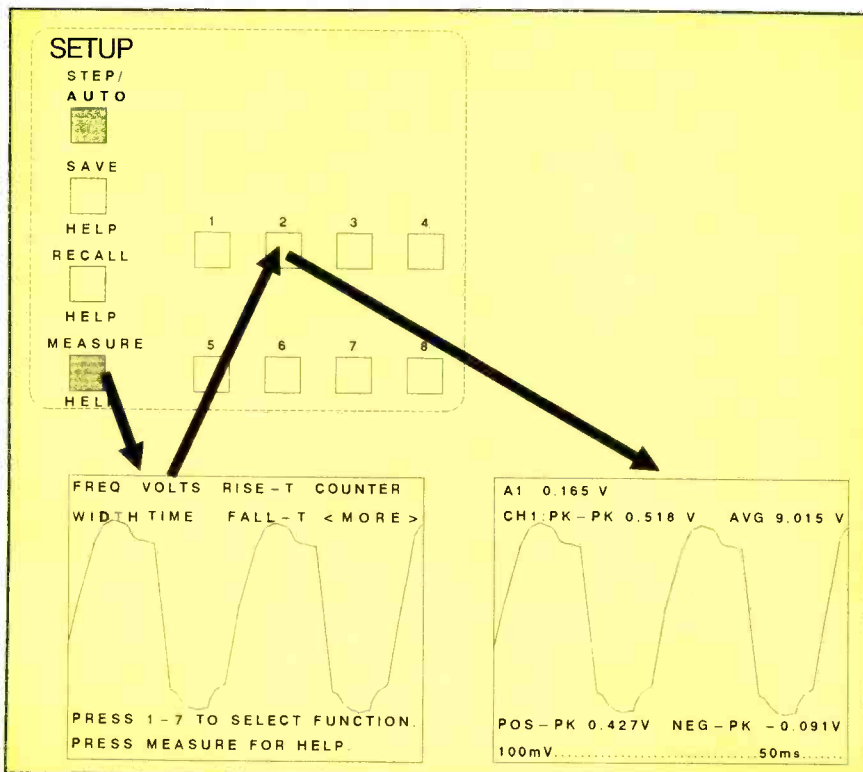

Figure 1. With the new automatic measurement capability, pushing two buttons sets up the waveform display and makes waveform measurements.



displayed waveform relative to the initial trigger point. This is the fundamental basis for horizontal time calibration on any analog scope display.

The next key to determining period in Figure 2 is the scope's ability to trigger on specific waveform points. This requires precision trigger control and trigger placement algorithms. The triggering system in a microcomputer-based analog scope can look at a waveform for peak-to-peak levels and then precisely select a 50% triggering level. This establishes a midpoint reference level on the waveform. By knowing the trigger point relative to the ramp, it also establishes a time from start-of-sweep to the first midpoint.

On subsequent sweeps of the waveform, the triggering system finds the next positive-going transition and its

50% point. This establishes a second time from start-of-sweep. The difference between this time and the time to the first transition is the period of the sine wave. The reciprocal of this, of course, is the sine wave's frequency.

All of the trigger positioning and time calculations are done automatically under internal microprocessor control. Because the calculations are differences relative to the initial trigger point, all input-channel and trigger-system delays subtract out of the final measurement. This feature enhances the accuracy of the technique.

The only limitation of the method essentially is that the waveforms being measured must be repetitive. It takes several sweeps of the waveform to find adjacent transitions and establish their midpoints. This limitation also explains

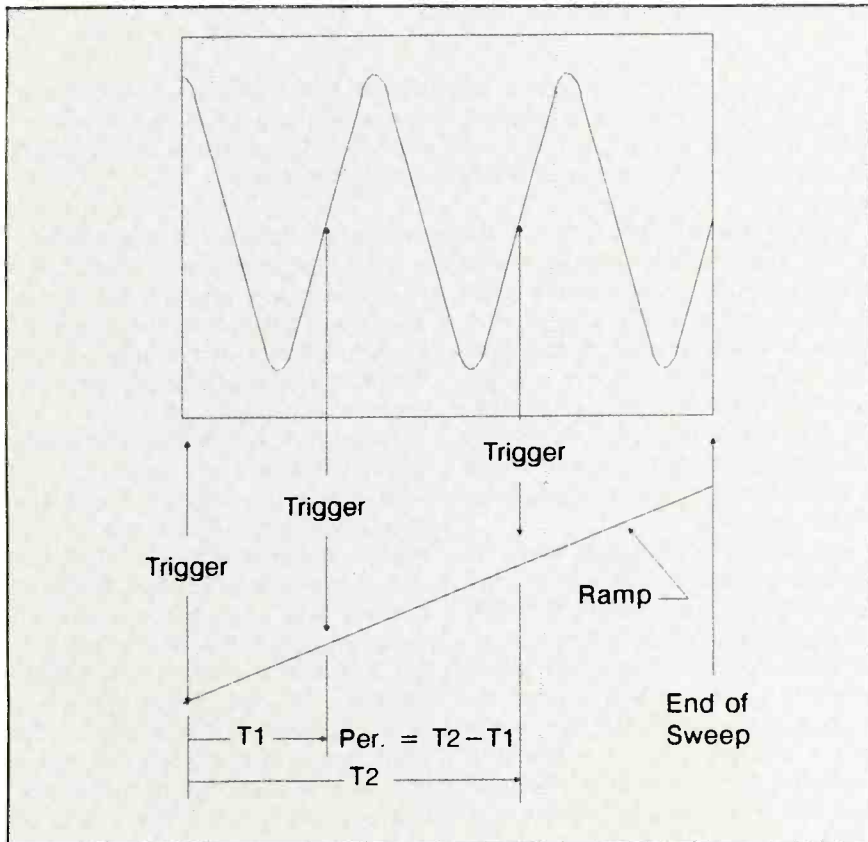

Figure 2. Trigger placement can be used to make a period measurement on a repetitive waveform.

# ATTENTION VCR TECHNICIANS



## VCR REPAIR PARTS KIT

Now you can do most of your VCR repair jobs the **same day**. Parts Express VCR Parts Kit makes this possible. It contains over 45 of the most commonly used parts to repair RCA, Hitachi, Fisher, Sanyo, Lloyds, Panasonic, Sony, Sharp, JVC, Samsung, TMK, GE, Magnavox, and more. Idler assemblies, pinch roller, sensing transistors, switches, and lamps are included in this comprehensive kit. You also save over \$20.00.

Kit contains replacements for: Sharp (2) NIDL0005, (2) NIDL0006, (1) NPLY-V0051, Panasonic (2) VXP0329, (2) VXP0401, (2) VXP0344, (2) VXP0521, RCA (1) 150614 (1) 164113, (1) 150650, Hitachi (1) 641311, Fisher/Sanyo (1) 143-0-4204-00300, (2) 143-0-4804-00100, (1) 143-0-4904-00900, (1) 143-0-741T-20002, RCA/Hitachi (2) up/down switch, (5) 161757 sensing transistors, Panasonic lamps (2) XAMQ27P150W, (5) XAMV0019, (5) XAMV125 (1) Molybdenum grease. Normal dealer cost of over \$110.00. (All parts are available individually for reorders.)

**\$89<sup>95</sup>**

Order #  
400-950

Plus shipping



## VCR IDLER TIRE KIT

This popular kit contains 170 of the most popular idler tires (10 each of 17 different sizes). With this kit in your stock room, you can do over 90% of VCR repair jobs the same day, saving time and money! Also included is our comprehensive cross reference listing over 80 manufacturers' assembly numbers and over 200 model numbers. A \$400.00 retail value. (All tires are available individually for reorders.)

**\$55<sup>00</sup>**

Order #  
400-900

Plus shipping

**FREE  
CATALOG**



**Parts  
Express**  
International Inc.

CALL TOLL FREE  
**1-800-338-0531**

340 E. First St., Dayton OH 45402  
Local—1-513-222-0173

Circle (16) on Reply Card

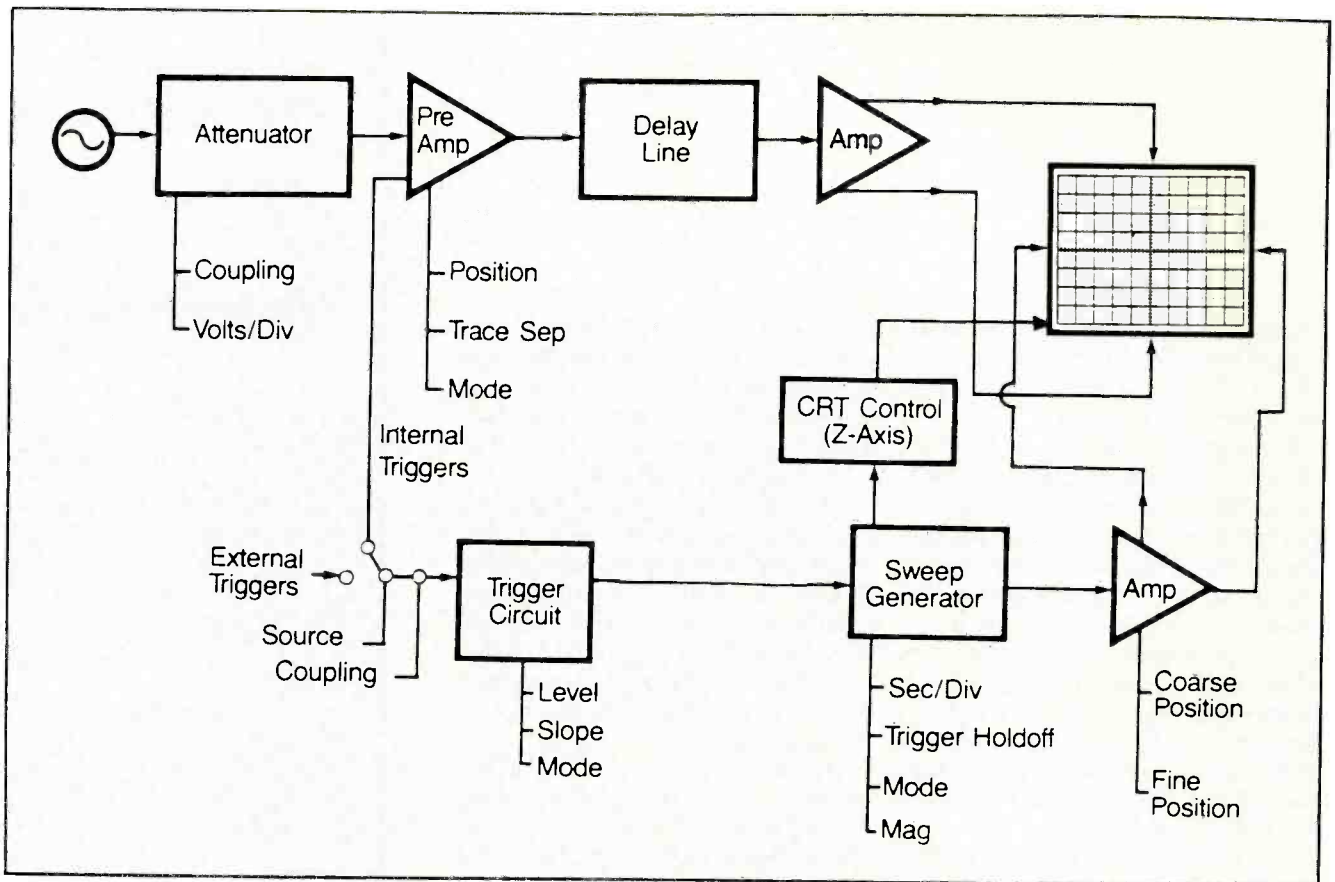

**Figure 3.** Many modern, sophisticated analog oscilloscopes are almost entirely digital instruments. The input channels, sweeps and triggers in today's advanced analog scopes are all microprocessor-controlled. That internal digital-processing capability, along with precision ramps and triggering control, provides the basis for the new automatic measurement capability.

the need for a highly stable triggering system. Because multiple sweeps are used, the scope must be able to trigger on precisely the same waveform points each time to avoid measurement jitter.

#### Making other automatic measurements

The same basic process illustrated in Figure 2 can be extended to other common timing measurements. On pulses, for example, pulse width is determined by trigger placement at the midpoints of two adjacent transitions. If the transitions are found to have a plus-minus slope order, the measurement is a +width for a "pulse high" condition. A minus-plus slope order results in a -width measurement. By setting triggering for the first three transitions on a pulse train, both the plus and minus widths can be determined. From these, both plus and minus duty factor can be computed.

To determine pulse rise or fall time, triggering is set to find the positive and negative peaks of the waveform. The trigger level information from these peaks is then used to compute the 10%

and 90% levels. Triggering is set to the 10% and 90% levels on subsequent sweeps, and the sweep ramp times to those points are subtracted to get rise or fall times.

Voltage measurements start out similarly by using the triggering system to find the positive and negative peaks of the waveforms. The trigger level values then correspond to the plus-peak and negative-peak values of the waveform. The absolute sum of these two gives the peak-to-peak value. Further steps with a special algorithm result in a value for the actual average dc value of the waveform.

With regard to average dc value, it's interesting to note that DSOs often compute a completely different value. DSOs usually find an average value by literally computing the average of the stored waveform points. At first glance, this practice seems reasonable. But for it to be the average value of a repetitive waveform, the stored values must correspond to an integral number of waveform cycles. If an average value is computed from one and a half cycles of a sine wave, the average is biased off by

the odd half cycle. This common pitfall is avoided when the average dc value is extracted directly from the repetitive analog waveform.

#### Everyday measurement capability

Most waveforms dealt with on a day-to-day basis are repetitive waveforms. The bulk of the measurements made on these waveforms are typically rise and fall times, widths, frequency, peak and peak-to-peak amplitudes.

This means that the bulk of the day-to-day waveform measurements — where designers, engineers and technicians spend most of their time — can now be done automatically with modern analog scopes that are based on digital circuitry. The scope probe is attached to the test point, the MEASURE button is pressed, a measurement type is selected. The rest, including display setup, is done automatically by the scope. So whether you choose an analog or a digital oscilloscope, you will be getting more automatic features that can make your job easier and more accurate.

**ES&T**

# Answers to the quiz

Questions are on page 22.

1. D — all of the choices are correct. However, once an amplifier circuit is designed, only the base current is changed during normal operation.

2. B — the product of the gains. Suppose the voltage gain of each amplifier is 10. The output signal of the first amplifier will be 10 times the input signal voltage. The output signal voltage of the second amplifier will be 10 times the output signal voltage of the first amplifier.

3. B — 0V. In the common-mode configuration, both inputs of the differential amplifier are identical. Therefore, the output voltage, which is related to the difference between the inputs, should be 0V.

4. B —  $h_{FB}$ . The capital letters used as subscripts indicate dc parameters. To get dc alpha, divide the collector current by the emitter current ( $I_C/I_E = \alpha$ ).

5. D — These diodes (diacs) will not conduct until a predetermined breakover voltage is reached.

6. D — none of the choices. Flicker noise, also called popcorn noise, is present in all amplifying devices. However, the mechanism for producing the noise is different for each component.

7. A — the one marked with an X.

The diode lead is always marked in some way.

8. See Figure F. The constant-current generator will deliver 60mA to a short circuit. Therefore, the short-circuit current is 60mA. That is one point on the load line. The open-circuit voltage is

$$V = IR = 60\text{mA} \times 50\Omega = 3\text{V}$$

That is the second point on the load line. The piecewise characteristic curve is drawn between 0.7V and the maximum rating of the diode (4V at 80mA). The current is determined by the points where the curves cross. The arrow shows that the approximate value is 25mA.

9. B — become more positive. Closing the switch causes Q1 to conduct harder and its collector voltage to decrease. That in turn causes the current through Q2 to decrease and makes its collector voltage more positive. The more positive voltage on the base of the PNP transistor reduces the current through it and makes point X less positive.

10. The statement is correct. An RC differentiating circuit can produce an output that is very nearly the differentiated waveform. (For more on this subject, see "What do you know about electronics?" on page 56.)

**ES&T**<sub>inc</sub>

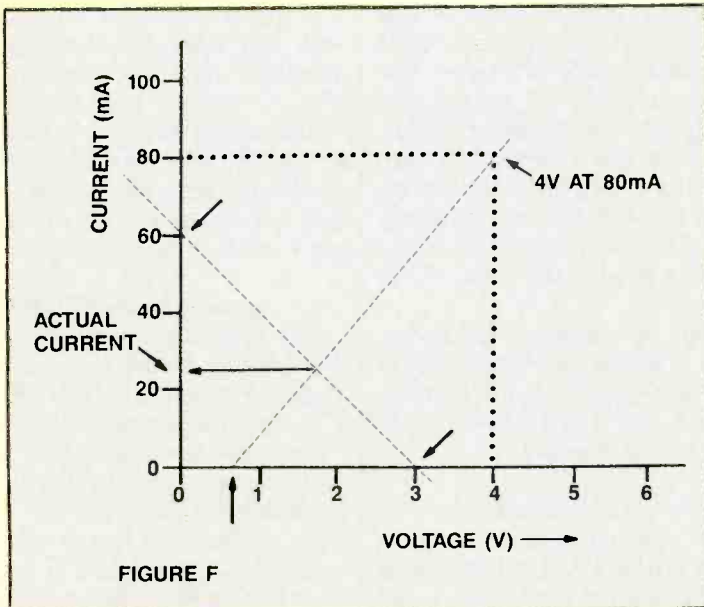

FIGURE F

# NEW FROM FLUKE



**Fluke 80 Series Analog/Digital multimeters do what no other handheld meter can do for you.**

Which is to say just about everything. Because it's the first multimeter that is capable of 12 different measurement functions plus digital, analog and audible readouts.

FLUKE 83	FLUKE 85	FLUKE 87
Volts, ohms, amps, diode test, audible continuity, frequency and duty cycle, capacitance, Touch Hold <sup>®</sup> , relative, protective holster with Flex-Stand <sup>™</sup>	Volts, ohms, amps, diode test, audible continuity, frequency and duty cycle, capacitance, Touch Hold <sup>®</sup> , relative, protective holster with Flex-Stand <sup>™</sup>	Volts, ohms, amps, diode test, audible continuity, frequency and duty cycle, capacitance, Touch Hold <sup>®</sup> , relative, protective holster with Flex-Stand <sup>™</sup>
\$199*	\$271*	\$259*
0.3% basic dc accuracy	0.1% basic dc accuracy	0.1% basic dc accuracy
5 kHz acV	20 kHz acV	20 kHz acV
Analog bargraph & zero	Analog bargraph & zero	High resolution analog pointer
Three year warranty	Three year warranty	True rms ac
		1 ms PEAK MIN MAX
		4 1/2 digit mode
		Back lit display
		Three year warranty

\*Suggested U.S. list price



For more information and immediate delivery call  
**Tool Kit Specialists, Inc.**  
today

(408) 745-6020  
(800) 621-0854 Ext. 202

Circle (17) on Reply Card

# The Scope model DVM-638

By Carl H. Babcoke, CET

Rare functions such as a Siemens test, capacitance measurements, continuity indicators, conductance measurements, level detections and transistor  $H_{FE}$  tests prove quickly that this digital multimeter (DMM) is not an ordinary instrument. The Scope model DVM-638 multimeter (available through Fordham) has 3½ half-inch-high LCD digits, an automatic negative-polarity indication, automatic decimal, a low-battery symbol and an automatic-overrange symbol (when you measure a value that's beyond the range that has been set, only the "1" at the left is illuminated).

Overall measurements of the meter are 3.3"x7"x1.5" and the weight is about 0.7 pound. It fits easily in the left hand, while the thumb operates the switches. Except for the two almost-white func-

tion switches and six dark-gray range switches along the left side, all other switches, jacks and sockets are on the instrument's front panel. One 9V alkaline battery powers the meter for as long as 150 hours.

## Dc-voltage specifications

The five dc-voltage ranges are 200mV, 2V, 20V, 200V and 1,000V. Accuracy is  $\pm(0.5\%$  of reading + 1 digit) for all ranges. Input impedance is 10M $\Omega$ .

## Ac-voltage specifications

The five ac-voltage ranges are 200mV, 2V, 20V, 200V and 750V. Except for the 750V range, all ranges have an accuracy rating of  $\pm(1\%$  of reading + 4 digits). Accuracy rating of the 750V range is  $\pm(2\%$  of reading + 4 digits). Input impedance is 10M $\Omega$  for all ranges, with a shunt capacitance of 100pF. The ac circuit is average sensing, and it is calibrated to the rms of sine waves.

Frequency response is about average for portable DMMs. Response at 500Hz was only about 0.1dB (0.4%) lower than at 50Hz. At 1kHz, the reading was -0.3dB (about -3.3%), and at 2.5kHz, the roll-off became a noticeable -1.6dB (about -11.1%). At 4kHz, the reading dropped to -2.9dB (approximately -28%). The last frequency measured was 10kHz with a low reading of -6.7dB (-54%).

Although acV readings are Scope-specified as flat only between 50Hz and 500Hz, many measurements at higher frequencies can be useful when higher precision is not required.

## Current specifications

Four dc current ranges are provided. Accuracy is rated at  $\pm(0.8\%$  of reading + 1 digit) for the 2mA, 20mA and 200mA ranges. Accuracy of the 10A

range is  $\pm(1.5\%$  of reading + 1 digit).

Ac-current ranges are the same as the dc-current ranges, except for the accuracy of  $\pm(1\%$  of reading + 4 digits) for the lower three ranges and  $\pm(1.5\%$  of reading + 4 digits) for the 10A ac current range.

## Resistance specifications

A full array of six resistance ranges covers 200 $\Omega$  full scale to 200M $\Omega$  full scale. In the high-voltage mode, accuracies of the 2k $\Omega$ , 20k $\Omega$ , 200k $\Omega$  and 2,000k $\Omega$  ranges are rated at  $\pm(0.5\%$  of reading + 1 digit). Accuracy of the 200 $\Omega$  range is  $\pm(0.8\%$  of reading + 3 digits), and the accuracy of the 20M $\Omega$  range is  $\pm(1.5\%$  of reading + 1 digit).

These six ranges also are available with low-voltage ohmmeter operation. The user just slides the Hi $\Omega$ Lo switch on the front panel from Hi to Lo position. Better accuracy is obtained with the Hi position.

A higher ohmmeter voltage (2.96V with open leads) is available for those situations when you want to forward-bias a semiconductor junction. You would use the meter's lower ohmmeter voltage (0.232V) when diode/transistor conduction is not desired and the circuit components surrounding a semiconductor need testing.

## Capacitance specifications

Five ranges cover capacitances from 2nF full scale to 20 $\mu$ F full scale. All five ranges have the same  $\pm(1\%$  of reading + 4 digits) accuracy reading.

For tests, capacitors are not connected to the Scope meter with the usual test leads and test jacks. Instead, connections are made to two small, plastic sockets (each with three pins, similar to those for transistors) that are located just above the test-lead jacks. You usually in-

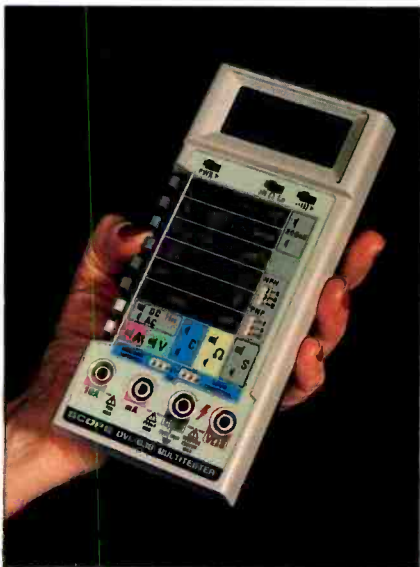

For portable use, the Scope DVM-638 meter usually is held in the left hand, thus permitting thumb operation of the edge-mounted switches.

Babcoke is the consumer servicing consultant for ES&T.

sert one lead of the capacitor into any hole of one test socket, then insert the other wire into any hole of the other test socket.

To select the approximate capacitance range needed, push in the two off-white switches (F1 and F2). Then look for a vertical column of (mostly) nF ranges printed in blue that is among the many listings on the meter's front panel. Push in the switch (R1 through R6) that corresponds with the capacitance range you want. If the reading obtained has insufficient resolution (not enough digits in the reading), push in the next lower range switch (smaller capacitance range). Repeat this until you get an overrange indication, then push in the next higher range. This range should give the maximum number of significant digits in the reading.

Reverse the procedure if the first reading overranges. Push in the next higher range switch, and continue with higher switches until a readout with the maximum number of significant digits is obtained. Remember the warning that is printed near the capacitance test sockets: Make sure that capacitors are discharged before measuring them.

### Diode tests

According to the operator's manual, the diode test reading for a good junction should show the forward voltage of the diode (approximately 0.7V for silicon semiconductors). Any other reading indicates that the diode is either open or shorted.

With this meter, the diode-test function is also the 2k $\Omega$  range in the array of six ohmmeter ranges. Therefore, the set-up, testing procedure and read-out are identical for the two functions. Maximum voltage with open test leads measured 2.96V, and the maximum cur-

rent with the leads shorted together was 1.286mA. These two standard test leads are plugged into the usual common and V- $\Omega$ -S test jacks.

Remember to select Hi ohms for this diode-testing function; Lo-ohms operation does not provide enough voltage for junction conduction. Also, remember that diodes conduct in only one direction. For conduction, the red test lead should connect to the diode anode; the black test lead is connected to the diode's cathode.

Reverse these polarities to conduct leakage tests. If the meter readout displays an overrange condition, the transistor or diode is good. If a numerical reading is displayed, the junction has leakage. If high-resistance leakage is suspected, change to the next higher ohmmeter range. If overrange is obtained, repeat by changing to the next higher range until a reading is obtained or the highest range is reached. Remember to use Hi ohmmeter voltage for all these tests.

### Testing the diode function

Accuracy of the diode-test function (there is only one range) was very good when fixed resistors were measured during preliminary tests. However, some inaccurate readings were noted with diodes. And when several diodes were connected in series, the readings were always less accurate.

Because the forward voltage across the base-emitter and base-collector junctions of a transistor may differ somewhat, in performing transistor-junction measurements, I measured both and divided by two to arrive at an "average" value. When I measured germanium transistors in this manner, the Scope's reading of 0.243V was 39% lower than the 0.401V reading obtained



Small capacitors can be plugged into two 3-pin sockets for capacitance tests. A special test lead for transistor/capacitance testing is available.

using the reference meter. When I measured the junctions of a silicon transistor in the same manner, the meters gave identical "average" junction voltage readings of 0.750V.

However, with several junctions in series, the Scope readings were higher than they should have been. When a reading for two diodes in series was 1.350V on the reference meter, the Scope reading was 1.646V (about 22% higher). With three diodes in series, the reference-meter reading was 1.701V, but the Scope was in overrange (above 1.999V). Incidentally, the reference-meter reading was the sum of the individual junction voltages, but the Scope reading was higher than the sum of these same junction voltages.

Perhaps you wonder why the diode readings are rated in dc voltage and not

in ohms, even when the diode readings are obtained from the 2kΩ range. One reason is that the operator's manual says the read-out shows "diode forward voltage." Also, we need to know the amount of voltage drop across diode or transistor (such as base-to-emitter). This voltage drop across a solid-state junction indicates the material of the transistor or diode. For example, junctions measuring around 0.4V (old production transistors measure much lower — around 0.3V) surely are germanium. Junctions having more than 0.6V are certain to have materials of silicon. Incidentally, over several years I don't recall having tested a silicon diode that showed a voltage drop of less than 0.50V or a transistor junction above 0.95V. Although those readings might not hold true for extraordinary types, the majority of diodes and transistors used in television, radio and tape-recording equipment probably will fit those limits.

Some of the peculiar readings in some data tables we produced by comparing DMMs were clarified by the following discoveries about diode-testing differences.

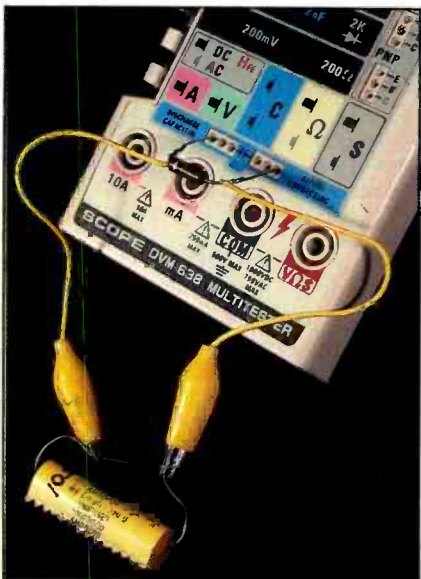

If the Fordham capacitor test leads are not available, a simple adapter for accommodating tubular capacitors can be constructed easily. Solder short test leads to a 15MΩ small resistor, which is plugged into the capacitance sockets. (Caution: This or any small adapter adds capacitance to the reading, which must be subtracted from the LCD reading when accuracy is desired.) This sample adapter added 0.016nF (or 16pF) to all capacitance readings.

Digital multimeters usually include one of two types of diode-testing circuits. Each has three major characteristics that allow easy identification.

The first type has:

- its diode function combined with an ohmmeter range.
- variations of testing current in step with the readings.
- an LCD readout that does not show the exact test-probe voltage during ohmmeter tests, although sometimes the two are almost the same. The model DVM-638 Scope meter has this type of diode tester.

By comparison, the second type of diode-testing circuit has:

- a diode function that is separate from all ohmmeter ranges.
- regulation of the current, so each reading has the same amount (this is called *constant current*).
- an LCD read-out showing the exact dc voltage coming from the test probes. Our laboratory reference meter has the constant-current type of diode test range. "Junction voltage-drop produced by constant current" is a longer, more accurate name for the constant-current test.

Electrically, this method is simple: A constant current is passed through a forward-biased, solid-state junction while a dc voltmeter measures the voltage that is produced by the constant current flowing through the resistance of the junction. Notice that all three elements for Ohm's Law are present. Also, the voltmeter is across the junction being tested, and the junction is connected to the test leads. Dc voltages on the read-out and at the junction/test leads are identical. For leakage tests, change to normal ohmmeter ranges. Reverse the test leads for reverse-bias leakage tests.

#### Conductance specification

Briefly, the Scope conductance function uses the 200ns range with an accuracy of ±(3% of reading plus 10 digits) to provide an equivalent-resistance range between 5MΩ and 10,000MΩ.

Conductance is the measure of a component's ability to conduct electricity. The conductance formula for dc circuits is written as the reciprocal of the

resistance. That is, conductance = 1/R (where R is the resistance in ohms). Over many years the short expression (for use in calculations and formulas) has changed. It originally was *mho* and now it's *Siemens* (abbreviated to S).

When the 200ns range is used, the formula is 1,000/ns = MΩ. To operate this function, simultaneously press in and lock the two top pushbuttons (R5 and R6); this action produces the 200ns range. Also, push in and lock the bottom gray pushbutton (F1), making certain the second-from-bottom gray pushbutton (F1) is in the out position, and turn the power switch on. Use the normal test probes and test jacks to obtain a reading. Calculate the conductance in megohms by using the ns-divided-into-1,000 formula. The operator's manual shows a graph that provides answers without calculations.

This conductance test is used for all extremely high-resistance measurements, such as testing for leakage in cables, copper circuit boards, diodes or small capacitors.

You'll get an overrange indication if it turns out that the point at which you're measuring is a short circuit or has a resistance below 5MΩ. If this occurs, change the switches and take a normal ohmmeter reading.

Perhaps the Siemens name is new to you, as it was to me. This apparently is another example of the trend toward renaming common terms after pioneers in the electrical field. William Siemens (1823-1883) was an engineer and inventor who, although born in Germany, moved to England where his excellent work in the electrical field was accomplished.

#### Continuity indicators

When you want to make continuity checks, you can set the meter to give you an audible tone as well as a visual readout whenever you probe across a point of low resistance. This continuity feature is available on all six resistance ranges. Whenever the resistance between the probes is very high (open circuit), an UP arrow and the single "1" digit (indicating overrange) appear on the display. When you probe across a circuit point that the meter considers to be approaching a short circuit and the probes remain in contact for 50μs or

longer, the UP arrow is replaced by a DOWN arrow and the 3.5kHz audio tone sounds. If you prefer, you can turn the tone off by the sliding switch on the panel.

On most meters, you will usually get a continuity indication only when the resistance across the probes is very close to zero. With the Scope, however, the resistance you're probing doesn't have to be very close to  $0\Omega$ . With this meter, the amount of resistance that gives a continuity indication depends on the range in use. For example, with the  $200\Omega$  range, resistances lower than  $470\Omega$  give a continuity indication. On the  $20M\Omega$  range (the highest on the meter), resistances below  $2.5M\Omega$  resulted in a continuity indication. A pulse stretcher operates for the  $20M\Omega$  range, so any continuity activates the indicators for approximately 100ms. This stretching is very noticeable to the ear and should be helpful.

Because the normal function of the ohmmeter ranges is not affected, when resistance of the continuity does not reach the overrange point, the numerical reading of the resistance is shown on the LCD readout.

During tests of this continuity feature, the DOWN arrow and the tone were activated regardless of how briefly the probes were touched together. This is good performance, and it should help the user find intermittent opens and shorts. The only negative observation was that the tone is not very loud, so if you have any kind of hearing impairment or if you are working in a noisy location, you might have to rely on the arrows as much as possible. Of course, reliance on the tone is excellent for times when a technician must watch where he places the test probes. This should be a popular feature.

#### Level-detector operation

The level-detector operation can sense and indicate logic levels in signals having an amplitude of less than 250V.

To use this feature, set up the meter as if you are measuring resistances, but select the  $200k\Omega$  range. This range supplies approximately +0.8V for the level detector to use as a standard for comparison with the incoming signal's level. Both visual and audible indications will operate unless the tone is switched off.

# This book can save your company a lot of money.

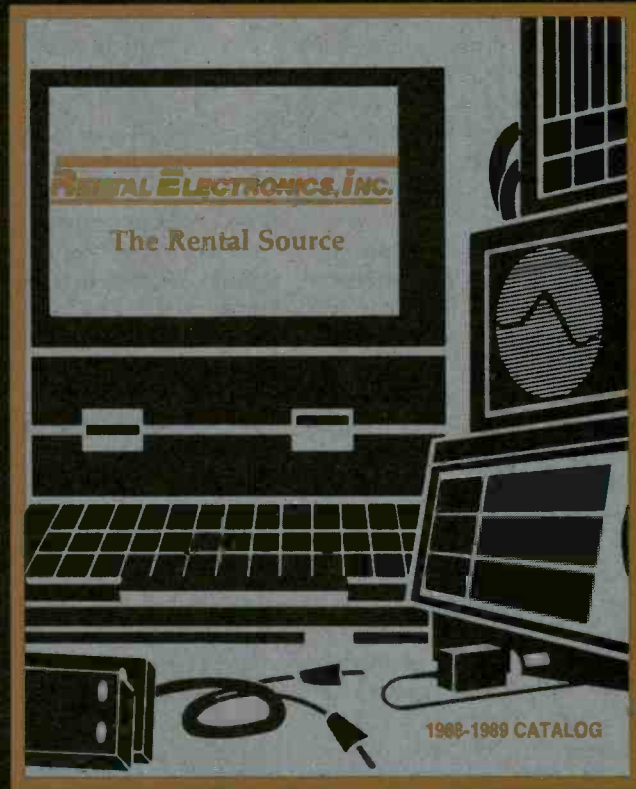

## It's free, too.

**GENSTAR**  
**RENTAL ELECTRONICS, INC.**

**(800) 227-8409**

**In California (800) 331-3440**

*This coupon will get you the information you need... fast!*

- Send me a free Rental Catalog.
- Include a catalog of like new products you have for sale.
- Call me immediately at: \_\_\_\_\_
- The equipment I'm most interested in is: \_\_\_\_\_

NAME \_\_\_\_\_ TITLE \_\_\_\_\_  
 ORGANIZATION \_\_\_\_\_  
 ADDRESS \_\_\_\_\_ MAIL STOP \_\_\_\_\_  
 CITY/STATE/ZIP \_\_\_\_\_  
 TELEPHONE \_\_\_\_\_

**Complete coupon and mail to:** Genstar Rental Electronics, Inc., 6307 De Soto Ave., Suite J, Woodland Hills, CA 91367

EST 6/89 ©Genstar Rental Electronics, Inc. 1988

Circle (25) on Reply Card

When the incoming signal is more positive than +0.8V, the UP arrow in the LCD read-out is visible. When the signal is less positive than +0.8V, the tone sounds and the UP arrow is not visible. Different areas of incoming waveforms produce many combinations of visual and audible responses. These are explained in detail and illustrated with a drawing in the operator's manual, so they will not be repeated here.

#### Transistor-testing specifications

PNP and NPN small transistors can be tested for 0-1,000  $H_{FE}$  (dc Beta) values. Approximately 10 $\mu$ A of base current is applied during each test, and the supply voltage is about 2.8V.

There are two 3-pin sockets for small transistors on the right side of the panel about 2 inches above the test-lead jacks (which are not used for these transistor tests).

To set the meter for transistor beta tests, you push in the second dark switch from the top (R5) and adjust all other edge-mounted switches to their out positions. No other adjustments are required.

To perform this test, you plug the transistor into the correct PNP or NPN socket and read the value of  $H_{FE}$  on the LCD read-out.

This feature was tested against several transistors formerly checked on an old (but good) dc-Beta meter, a model with several switches, variable control and a precision meter. The value of dc beta for one small silicon NPN transistor measured 220 on the older meter and 294 on the Scope. The beta of another silicon PNP larger-case transistor measured 28 on the older meter and 42 on the Scope. Readings from other small transistors compared in about the same ratio, with the Scope readings between 25% and 35% higher than those of the older, expensive meter.

Differences in readings of this magnitude are not unusual between dissimilar beta-testing meters. My limited experience has shown no two models producing the same dc-beta. These Scope readings are satisfactory, and the transistor-testing feature is excellent in many ways.

Incidentally, when a transistor is inserted in the socket with collector and emitter interchanged, the reading is very

low, perhaps 5 to 6. So if you obtain a beta reading of less than 10, turn the transistor around and believe the higher reading. Another cause of low readings is an open connection in one lead. Make certain that all three pins touch the socket securely.

One limitation of the Scope transistor-testing procedure is the difficulty or impossibility of inserting some transistors into the small sockets. No solution for this problem is found on the DMM, but a special cable for connecting the pins externally can be ordered from Fordham. Details of these transistor/capacitor connecting cables are provided later. Except for the difficulty

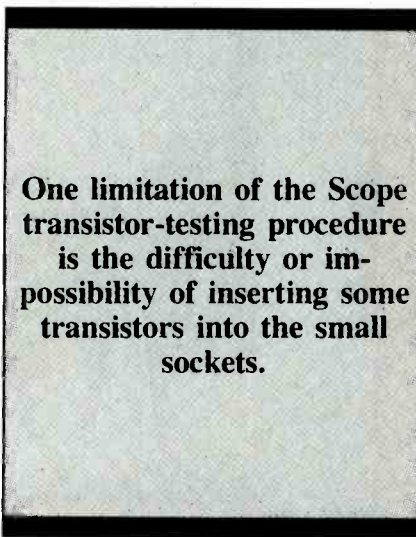

of connecting some transistors, the method of testing small transistors used by this meter is excellent. Tests for opens, leakages or shorts in transistors should be performed by using the normal resistance ranges and test probes.

#### Accessories

The Scope DVM-638 meter is supplied with four items: a 16-page operator's manual, a pair of test leads, a 9V zinc-carbon battery and a 0.8A fuse.

Two more useful additions can be obtained on order from Fordham Radio Supply. A CA-92 padded case is available for \$9.95. Also, an excellent optional item is the \$9.90 set of TL-216 test leads for transistor and capacitor tests. No samples were sent for evaluation, so they were not tested. But even without seeing them, I certainly would

want those specialized capacitor and transistor test leads. They should help any technician perform those tests more rapidly and make fewer mistakes.

#### Comments

Tests and examinations of the Scope meter were more extensive than is customary for items reported by our Test Lab. One reason for the extra tests is that this meter is the first off-shore model (it was manufactured in Taiwan) to be examined. Checks for accuracy of various functions were performed by simultaneously operating the Scope meter vs. two or three lab meters. Accuracy of at least one of the testing meters always was rated higher than the Scope's published accuracy. Perhaps this method could be called trial by its peers.

Dc voltages were tested by all meters at several fixed voltages from batteries. The Scope meter readings differed from the others only by one least-significant digit. Several ac voltages were tested, and again all meters were substantially in agreement. Accuracy of ac readings vs. frequency was covered before.

Resistance tests were made at 23 values, and the variation of readings between three meters was found only in the least-significant digit.

Capacitance tests were performed for 18 values, and some differences of meter readings were noticed. The Scope meter and another DMM gave nearly identical readings, while the third meter (which operates by a different principle) showed some readings that varied from the DMMs by perhaps 10%. Again, it is my experience that capacitance meters seldom show identical readings.

Very informative were tests designed to indicate changes of readings from various resistances placed in parallel with each of the 18 capacitors. Three capacitance values were chosen as sufficient to reveal the principle of resistance-load errors.

On the Scope meter, the smallest capacitor measured 1.286nF without a resistive load. This reading changed to 1.326nF with a paralleling 1M $\Omega$  load. The reading increased to 2.32nF with a 100k $\Omega$  load; to 6.25nF with a 47k $\Omega$  load; and to 20.2nF with a 15k $\Omega$  load. Finally, a 40 $\Omega$  load increased the reading to 7.76 $\mu$ F!

An 11.37nF capacitor showed an in-



crease with only a 100kΩ load. As the load resistance was decreased in steps, the meter reading increased to 31.2nF with a 10kΩ load and to 302nF with a 1kΩ load. Finally, a 40Ω load increased the reading to 7.77μF!

A nominally 0.1μF capacitor tested 96.2nF without load. The reading increased to 100.6nF with a 10kΩ load, and to 219nF with 1.5kΩ. For the last reading, a 40Ω load increased the reading again to 7.77μF!

Did you notice that one certain extremely high reading was shown with a 40Ω load for all three capacitances? Evidently, this is the reading for near shorts regardless of capacitance. Many readings were made but not shown here because these few showed the trend: Any resistive load increased the LCD reading, and smaller capacitances were more affected by resistive loads than were the larger capacitances.

Two major suggestions emerge from these tests: Don't measure capacitors in-

circuit, and be alert for a leaky capacitor that apparently has excessive capacitance. It appears likely that most other DMM capacitance functions will operate the same with resistive loads.

The subject of high- vs. low-ohmmeter voltages omitted some figures and comments. Starting with the 20kΩ range and high ohmmeter voltage, a 15.18kΩ resistor produced 1.721V across the resistor. With low voltage, the same resistor measured 15.19kΩ, but the voltage across it was only 0.129V. A 1.012kΩ resistor across the 2kΩ range measured the same on both high and low voltages, but the high voltage produced 0.801V while the low voltage produced only 0.525V. Tests on the higher ranges produced similar results.

On the 200Ω range with high voltage, a resistor tested 39.8Ω with 0.0726V across the resistor while the low voltage produced 40.1Ω with 0.034V. Apparently this range has different characteristics than the other ranges. Neither high- nor

low-voltage ohmmeter voltage cause diode or junction conduction.

These figures (and others not reported) should prove that the accuracy of the so-called low-voltage operation is equal to that of the high-voltage operation, except on the 200Ω range. Therefore, choose high or low operation according to the need for diode-junction conduction. Probably you will use high-voltage operation more often than the low-voltage, so it is recommended that you keep the switch at high position until low is needed.

Where is the decimal point? That is a question often asked when we want to change nanofarads to microfarads or picofarads. Most DMMs that have a capacitor-test function also show several ranges calibrated in nanofarads. Now, nanofarads is a valid rating, but many of us old-timers are not overly practiced in its usage. We usually jumped from microfarads to micromicrofarads (now called picofarads). Nanofarads is be-

## Excellent reliability and operational simplicity in a high-performance scope.

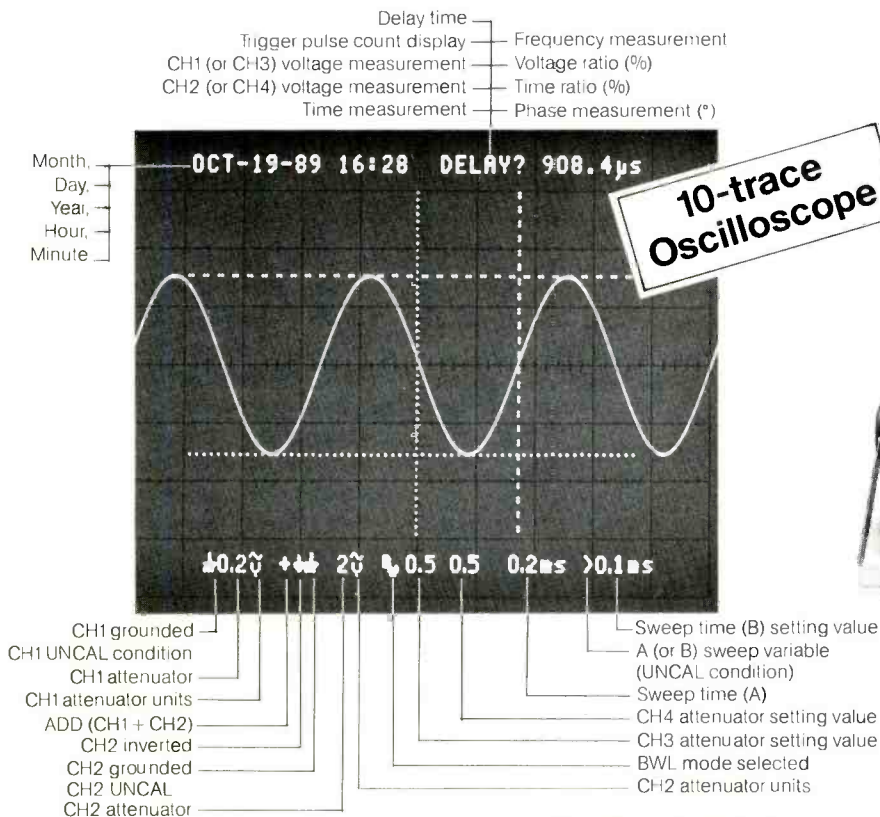

### CS-6020...150MHz 4-channel, 10-trace oscilloscope.

- A trigger counter function for analyzing complex digital and video signals.
- Bright CRT readout-all essential information on a single screen.
- Cursor functions--provides a digital readout of voltage, time, voltage ratio, time ratio, frequency, and phase differences.
- Logic control for functionality and high reliability.
- B sweep variable for line adjustment of delayed sweep.

For more information, contact your Kenwood Distributor or call Kenwood today!



## KENWOOD

KENWOOD U.S.A. CORPORATION  
Communications & Test Equipment Group  
2201 E. Dominguez St., P.O. Box 22745  
Long Beach, CA 90801-5745  
Telephone: (213) 639-4200

Circle (24) on Reply Card

tween the two, and it is very popular with the designers of new equipment.

For example, the Scope meter has four out of its five capacitance ranges calibrated in nanofarads (abbreviated nF). For those times when you want to change nF readings to pF or  $\mu$ F, here are the easy conversions:

- Change nanofarads to microfarads by moving the decimal three places to the left.
- Change nanofarads to picofarads by moving the decimal three places to the right.
- Change picofarads to nanofarads by moving the decimal three places to the left.
- Change microfarads to nanofarads by

moving the decimal three places to the right.

### Summary

After a first glance at the Scope DVM-638 meter, my immediate reaction was negative because of the complicated panel and its layout of switches. I wondered if a technician could memorize all of the steps necessary for the selection of each function desired and the range needed. Obviously, it is not practical to consult the operator's manual each time a function is changed. Also, the manual is too brief (having only 16 4½" x 6" pages) and sometimes confusing, as illustrated by the page-11 diagram that has six horizontal rows for

the test jacks to be used, two horizontal rows of 2-position function-selector switches, and six horizontal rows for range selection. These horizontal rows intersect with 14 vertical columns, making squares with markings in them to show the in-or-out position for the 14 functions.

Unfortunately, the layout of the manual diagram does not conform physically with the actual meter. For example, the F1 and F2 almost-white function-selector switches are at the bottom of the thumb-operated push switches on the meter, but they are shown at the top on the manual's diagram. Also, the R1-through-R6 range-selection switches on the meter are reversed in the diagram. As you can easily imagine, this promotes confusion when a technician is trying to use the manual to locate the necessary switch positions for a transistor test (for example).

Fortunately, the manufacturer has provided several pictorial diagrams inside colored areas on the front panel, and these show the in-or-out positions of the two function-selector switches (F1 and F2). After a technician has used these suggestions (or consulted the manual's page-11 diagram) and operated the meter through all 14 functions, he should be able to select and use all 14 functions solely by "reading" the meter's panel.

In conclusion, the Scope DVM-638 digital multimeter performed very well in all tests, with a few minor exceptions (such as errors at the extreme ends of the diode range, and others noted before). These few deviations from perfection should cause no problems for most users. They are small prices to pay for the several important extra features that have been added above those of the average DMM without increasing the size or weight of the meter. The strong points far outweigh the few weak ones.

It is a meter that should be a welcome addition to any shop or lab, and its reasonable price is an extra bonus.

*Editor's note: The Scope model DVM-638 DMM is listed on page 12 of the 1989 Fordham catalog for \$87.50. Also listed are the \$9.95 CA-92 padded case and the \$9.90 TL-216 test leads for transistor and capacitor connections to the meter.*

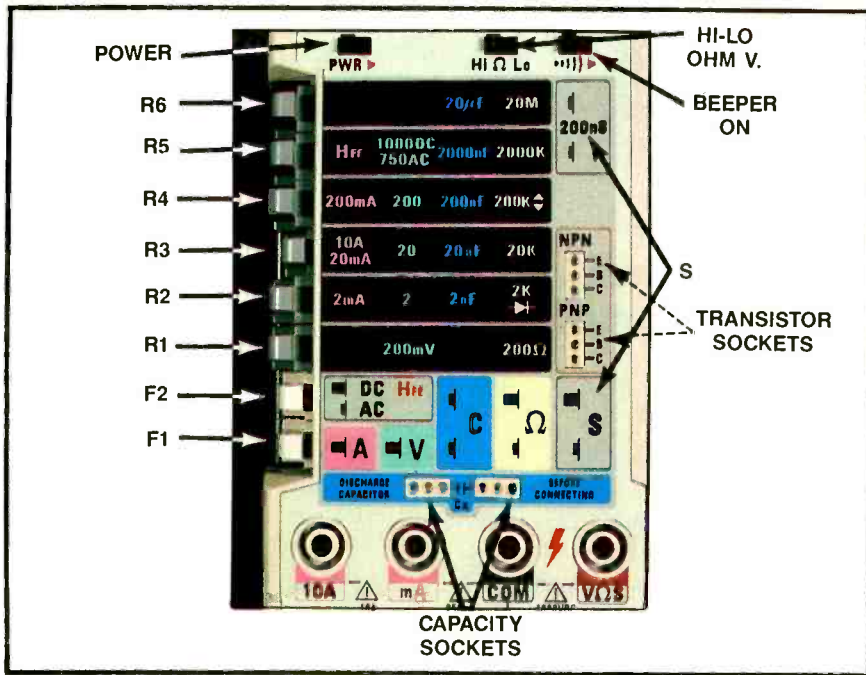

Inside the black rectangular area near the center of the meter's panel are four vertical columns or ranges. On the left (printed in pink) are the current and  $H_{FE}$  ranges. Next, printed in green, are the dc-voltage ranges. The blue third column has the five capacitance ranges. And in the fourth column, printed in pale green, are shown the six resistance ranges, with a diode symbol placed below the 2k $\Omega$  range. These ranges are selected by the five dark-gray switches (R1 through R6) that are horizontally in line with the rows of ranges. When one of these switches is depressed, all others return to the out (or off) position. Only one at a time, therefore, is activated. The only exception to this scheme is when the "S" conductance range is selected. In this case, you press in the top two switches simultaneously. (When you want to enter another mode, pressing any other button releases both "S" switches.)

Below these six switches are two almost-white switches (F1 and F2) that are used for selecting the various functions by their in or out positions. These two do not interlock together but can be adjusted separately. Arrows on the photograph show the locations of other switches and sockets.

Drawings showing the in or out position for various functions are in horizontal lines at the right of F1 and F2 function switches. Therefore, in normal operation, F1 and F2 are adjusted according to the drawings on the panel. The range for that function is then selected by pressing in the desired R1 through R6 range switch. Color blocks with the drawings inside help to match the function and the vertical columns of ranges.

With these helps, reference to the operator's manual seldom should be required.

# Products

## Portable oscilloscope

Tektronix has introduced its 2211 portable oscilloscope, which provides 50MHz bandwidth and 20MS/s sampling rate/channel. The scope features 8-bit vertical resolution, 4K record length per channel, on-screen cursors, CRT readout and a hardcopy serial interface. The model is well-suited for low-frequency and single-shot measurements.

Circle (75) on Reply Card

## Z-Meter demonstrator

The DM115 Z-Meter demonstrator from Sencore provides "faulty components" that allow the user to learn how the Z-Meter tests indicate capacitor and inductor failures. Capacitor tests simulate good, shorted and open components and excessive value changes, leakage, dielectric absorption and

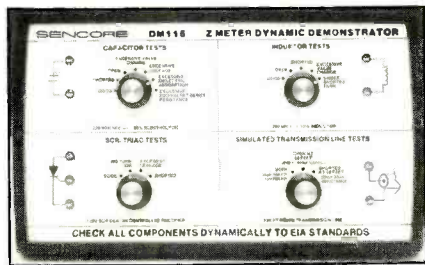

equivalent series resistance. Inductor tests simulate opens and shorts, excessive value changes and a single shorted turn. SCR and triac tests simulate good, no turn-on, excessive leakage and shorted conditions. Simulated transmission line tests illustrate how to use the tester to determine the distance to an open or short in a transmission line.

Circle (76) on Reply Card

## Diagnostic tool

The VU-THRU from Prime Electronics is a clear jig that allows a VHS machine to be operated as if there were a tape in it. The tool blocks sensors and makes switches and contacts, allowing the servicer to check the idler and spindle and brake action.

Circle (77) on Reply Card

## Soldering station

The Weller MC5000 microprocessor-controlled soldering station, available from CooperTools, allows the use of two different sizes of tools and 34 different tip styles with no recalibration. The station is programmable to allow for tip

temperature accuracy and stability. Tip style changes are input on the keypad as a menu function. Tip temperatures are controlled to within  $\pm 3^\circ$  to  $5^\circ\text{F}$ . A temporary automatic setback feature moves tip temperature back to  $350^\circ$ . The non-volatile internal memory stores enough information to control set temperature, tip style, display mode, station and tool calibration.

Circle (78) on Reply Card

## Oscilloscope

Leader Instruments has introduced the model 1021 20MHz oscilloscope with an ergonomic front panel. Triggering controls include variable trigger hold-off, TV-V and TV-H sync separators, LF-Reject, HF-Reject and line triggering. Other features include 1mV sensitivity, an internal graticule, auto-focus and scale illumination.

Circle (79) on Reply Card

## Parts storage cabinets

Contact East has introduced three portable, small-parts storage cabinets. The cabinets are made from high-impact plastic and feature rustproof hardware, removable drawers and a self-storing door that double-latches to prevent drawers from opening.

Circle (80) on Reply Card

## Soldering iron sleeve

The Iron Sleeve from Electron Processing allows electronics servicers to place hot soldering irons back into their toolkits without waiting for the iron to cool. The sleeve is an 11-inch long, 1.5-inch diameter tube of proprietary heat-absorbing mass.

Circle (81) on Reply Card

## Torque wrench

The T-Torker ratcheting, T-handle torque wrench from Lowell features a self-locking, reversing collar that disengages the ratchet mechanism for conventional backing-off and loosening. The wrench is factory preset from 5 inch-pounds to 80 inch-pounds and has  $\pm 10\%$  accuracy. It can be supplied with a hex socket set and various screwdriving bits.

Circle (82) on Reply Card

## Static-shielding bag

The 2100E and 2110E recloseable, static-shielding bags from 3M protect against all three types of electrostatic

charge and safeguard against corrosion and contamination. A proprietary fluorochemical agent is compounded directly into the polyethylene inner layer that disperses charge throughout the interior of the bags as it is generated, eliminating the need for surface lubricants that can corrode sensitive electronic devices. The bags are also embossed in a waffle pattern to minimize triboelectric charge and to ease insertion of boards.

Circle (83) on Reply Card

## A-V setup video

Reference Recordings has released an interactive laser videodisc, "A Video Standard," that is an audio/video reference for the setup and alignment of home entertainment, video monitor and projection systems. It contains audio and video test signals with instructions on how to use them, plus a variety of audio and video demonstration material.

Circle (84) on Reply Card

## Digital multimeter

The DM310 33-range, ruggedized DMM from Universal Enterprises has a resolution on the most sensitive ranges of 0.1mV, 0.1mA and 0.1 $\Omega$ . The DMM can withstand a 7.5-foot drop and has a 1/2-inch-high LCD. Features include a

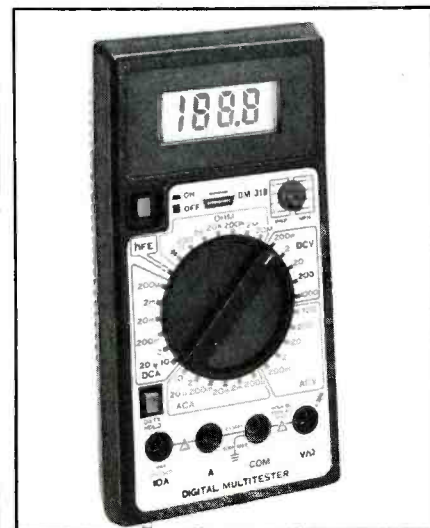

data hold button, auto polarity, over-range indication and an audible continuity buzzer. A line of optional accessories allows the user to measure light levels, temperature range, microwave diode assemblies, RPM, humidity, flame safeguard relays and ac/dc current.

Circle (85) on Reply Card

ES&T

# HDTV proposal meets all key criteria

High-definition television (HDTV) is generally described as a new, consumer-oriented television service that will offer improved picture resolution (typically twice the horizontal and vertical resolution that can be achieved by the current U.S. TV broadcast system) and improved audio (usually defined as being as good as an audio compact disc).

Other characteristics of an HDTV system could include reduced picture noise, wider screen dimensions (also called a wider *aspect ratio*) and larger screen sizes.

Adapted from a Zenith paper.

A number of approaches to implementing HDTV are being explored worldwide. One approach has been proposed by Zenith. According to Wayne Luplow, executive director of electronic systems research and development for Zenith's Consumer Products Group, the "ideal" HDTV system should — at a minimum — provide improved picture resolution and higher-quality sound for owners of a new generation of HDTV sets. It should also continue to provide a high-quality signal for the more than 160 million TVs in U.S. homes today.

The existing U.S. TV broadcast system, which has a 6MHz channel

bandwidth, is known as NTSC (for the National Television Standards Committee that established the system in the 1950s). HDTV systems that will continue to work with sets built around the NTSC standard are often called "NTSC-compatible."

A number of NTSC-compatible HDTV systems have been proposed, but according to Luplow, "Until now, not a single one has satisfied all of the key criteria simultaneously: no adverse impact on existing television reception, a picture that has four to five times as much information but is still within a 6MHz signal, and a signal that's robust enough to be transmitted and received cleanly without noise and other distortion."

## Spectrum-compatible HDTV transmission

Zenith's research and development team in Glenview, IL, has designed a transmission system to satisfy all of the performance, co-existence and spectrum-availability conditions specified above.

Under the NTSC standard, many channels are not used in any given area because, to prevent interference problems, the FCC does not assign a large number of positions in the spectrum (particularly in the UHF band). In most metropolitan areas, spectrum use is restricted to every other VHF channel and every sixth UHF channel.

In developing a new HDTV system, Zenith found a way to leave NTSC station operations intact so that existing TV sets could still be used without signal compromise. The new transmission technology of this system is consistent with existing 6MHz channel allocations but will allow the use of unallocated TV channels in the VHF/UHF spectrum.

The result is that every existing NTSC broadcast station could obtain a second 6MHz channel over which a true HDTV program could be broadcast at the same

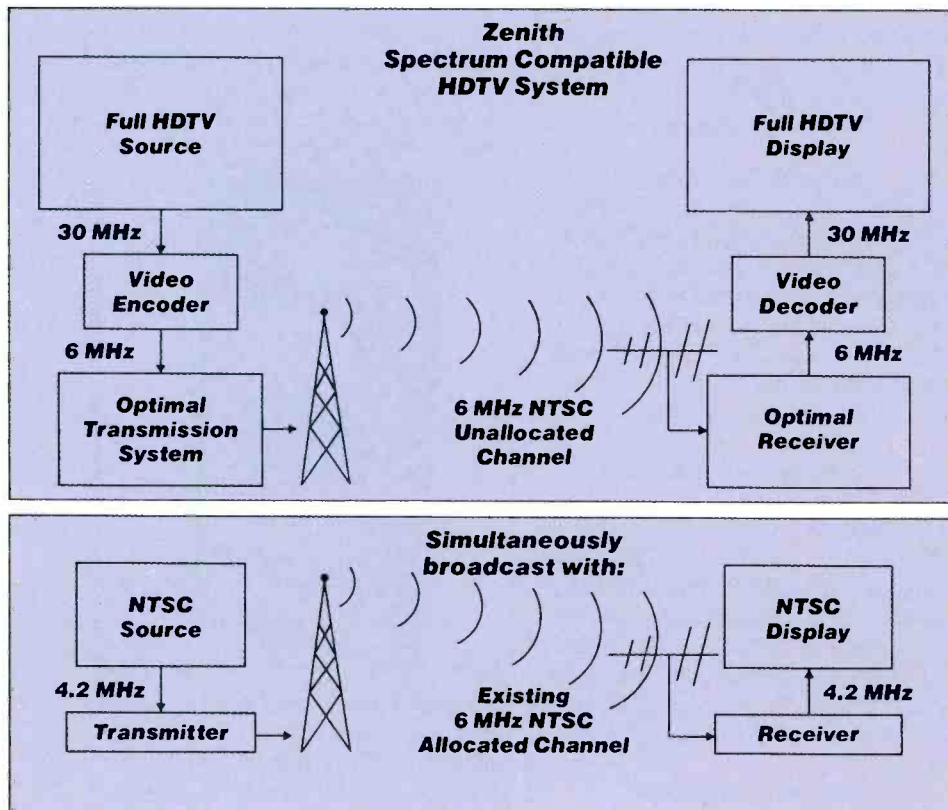

Figure 1. Converting the low-frequency video signal to digital form permits an HDTV broadcast that uses substantially less power and will allow the use of unallocated TV channels in the VHF/UHF spectrum. Existing NTSC broadcast stations could obtain a second 6MHz channel over which a true HDTV program could be broadcast at the same time as existing NTSC programming.

time as existing NTSC programming. Thus, this HDTV system is *spectrum-compatible* with existing NTSC signals.

### The Zenith transmission system

To achieve this spectrum compatibility, the Zenith system separates the HDTV picture information into two frequency bands. The high-frequency portion (above 200kHz) of the HDTV signal will continue to be transmitted in analog format, but video frequencies below 200kHz will be converted to digital form and then transmitted more efficiently in conjunction with the high-frequency analog signal.

Transmitting the standard high-frequency portion of a video signal uses less than 1% of the energy needed for a complete broadcast signal. Virtually all of the power required to send a video signal is needed for the low-frequency video information, plus the synchronization information (which is also low-frequency) and the average (or dc) value of the video.

Converting the low-frequency video signal to digital form permits an HDTV broadcast that uses substantially less power, essentially eliminating interference with other television signals (either on the same channel, adjacent to the HDTV signal or located elsewhere in the VHF/UHF spectrum). At the same time, the system yields a signal-to-noise (S/N) ratio that is better than the NTSC ratio.

This HDTV system also allows the sync and dc components — which are sent continuously and thus redundantly in NTSC — to be sampled at a low rate and digitized.

The low-frequency video information, two channels of digitized CD-quality audio, and the sync and dc information are then transmitted in the vertical blanking interval.

To help eliminate ghosts and other distortion, the digital data is encoded using error-correcting circuitry. The

digital audio will be encoded using systems proposed either by Digideck or Dolby. A small amount of RF carrier is added back into the system to allow signal acquisition and tuning of the receiver. Extensive digital signal processing will be required in HDTV receivers based on this system, but it is expected that only 1Mbyte of field (frame) memory will be needed.

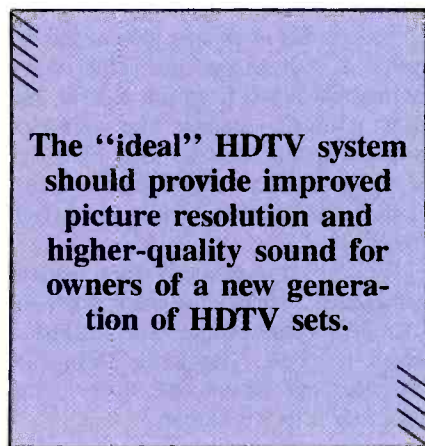

“We’re effectively taking 30MHz of complex video and audio data and squeezing it into a 6MHz channel that has no negative impact on the channels around it,” Luplow said. “Yet, with additional processing, that signal can be made quite robust.”

One benefit of Zenith’s HDTV system is that average transmitter-power requirements are reduced by more than 90% compared to an NTSC transmitter with the same service area.

### The encoding system

The system’s encoding technique, which makes it possible to transmit about five times the NTSC information through a 6MHz channel, is based on the properties of the human eye. Because the eye’s ability to perceive detail is considerably less for moving objects than for non-moving objects, the system transmits stationary video at high

resolution, but motion video at lower resolutions, thereby conserving bandwidth.

Although the transmitted HDTV signal will resemble an NTSC transmission for spectrum compatibility, the HDTV display on home receivers will be a 787.5-line, progressively scanned 59.94Hz display, comparable in resolution to an interlaced display of greater than 1,000 lines. NTSC offers a 525-line, interlaced display of 262.5 lines per 59.94Hz field.

As a source for these 787.5-line HDTV transmissions, broadcasters can use either a 787.5-line, 59.94Hz format in a 30MHz RGB signal, or a 1,050-line, 59.94Hz format, which is then electronically compressed to be compatible with the 787.5-line display.

The system is capable of providing TV images with various width-to-height aspect ratios, such as 16:9, 5:3 or 4:3.

### Cable, satellite and VCRs

The reduced average power and peak power of the Zenith system also allows cable systems to send 6MHz HDTV signals with improved interference and S/N ratio characteristics — without rebuilding cable plants or decreasing the number of available channels.

Because these HDTV signals are directly transcodable to the FM signals used in satellite broadcasts, the resulting signal improvements could lead to smaller receiving antennas (dishes) in a direct broadcast satellite (DBS) environment. And satellite transmissions of network HDTV feeds could occur over existing NTSC links.

VCR technology also could be extended to incorporate this system. Because 6MHz of bandwidth is all that is needed to record the full HDTV signal, only modest improvements over Super VHS technology will produce HDTV VCRs, and consumers with existing VCRs will still be able to tape NTSC broadcasts.



# What do you know about electronics?

## Quiz feedback

By Sam Wilson, CET

I received a nice, professional letter from James Wagner of Park Ridge, IL, about the February 1989 "Test Your Electronics Knowledge." As sometimes happens, errors did creep in. I want to devote a few lines to those errors. Also, I've revised the questions and put them in the quiz for this issue.

From question number five in the February quiz:

"In the Class A circuit in Figure B [Figure A in this issue], R3 is open. That will cause the voltmeter to read: A. 0V.

B. a higher-than-normal voltage."

My comment: There isn't any logical place that you can put a voltmeter that changes its measurement to 0V when R3 opens. That eliminates choice A. Although there was no voltmeter shown in the illustration, it would have to be between the emitter or base of the transistor and ground. Both of those points become more positive when R3 opens.

There was also a problem with the answer to question number nine:

"Bandwidth is the range of frequencies between points where voltage is down by 70.7%. It is also the range of frequencies between points where the power is down 50%. Which of these represents -3dB?"

The answer was given as follows:

"Both represent 13dB:

$$\text{dB} = 10 \log 0.5 = -3.01$$

$$\text{dB} = 20 \log 0.5 = -6.02$$

Both solutions in the answer show that the correct answer is 3.01dB. That was the point of question: The dB values are the same for voltage vs. frequency and for power vs. frequency graphs. The 13dB value occurred when the minus sign was accidentally changed to a 1. That was a printing error.

In question number 10, the value of the applied voltage and series resistance were omitted. The question was:

"The silicon diode to be connected across this circuit in Figure D has a maximum-value rating of 50mA at 2V. How much current will flow when the diode is connected into the circuit in Figure D?" [See Figure B in this issue.]

Wilson is the electronics theory consultant for ES&T.

The answer to the question said: "10.9mA. This problem is easily solved with the piece-wise method. You know two points on the characteristic curve: The breakover point is 0.7V and the maximum value is 2V at 50mA. They are marked with an X and the characteristic curve is drawn as shown in Figure E. [Figure C in this issue.]

The load line is drawn between the 5V open-circuit voltage and the (5/200)mA short-circuit current. The curves cross at the solution, showing that the current with the diode connected is 10.9mA. The voltage will be 1.2V."

You could, of course, determine the value of voltage and the value of the series resistance from the answer, but you couldn't answer the question without seeing the load line. That was a regrettable error that I made when I copied the drawing from my rough sketch.

We really appreciate it when readers send letters, whether the letters point out mistakes or make suggestions, or just to keep in touch. The letter from Mr. Wagner, and others like it, give me motivation to try harder.

### The conductron

A good friend, Delbert Shafer of Warren, OH, sent some components that look something like fuses. My rough sketch is shown in Figure D. His question: What are they?

He doesn't remember this, but he gave me two of those many years ago when I was teaching at Kent State University. Recently, he sent two more.

The resistance between the terminals is 0Ω. It was measured with a very accurate Kelvin bridge.

I've shown them to many people and no one had any idea about them. Recently, I ran across another friend who said he thought he knew, but he made me promise not to mention his name in case he is wrong.

Don't bother to write and ask his name. When I tell my friend Daniel Loper that I won't mention his name, my lips are sealed.

Anyway, our guess is that these

devices are simply conductors that patch between two connectors. They could also be used as fuse-like holders to connect circuits. Using these devices, it is also easy to disconnect circuits in various places.

That was a good guess made by a friend and me. Do you have a better idea? Please send it. I won't mention your name if you don't want me to.

### If it ain't air, don't inhale it

Not long ago, I wrote about the very

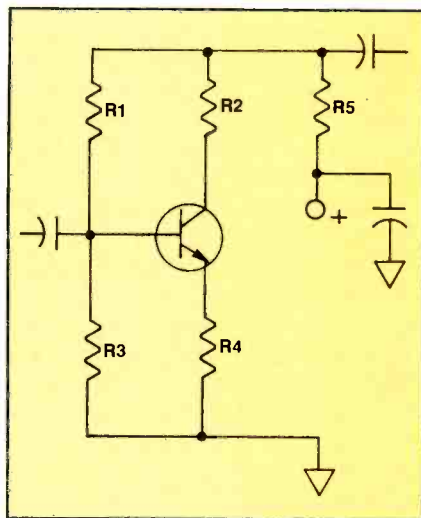

Figure A. There isn't any logical place that you can put a voltmeter that changes the measurement in this circuit to 0V when R3 opens. If a voltmeter were connected, it would have to be between the emitter or base of the transistor and ground. Both of those points become more positive when R3 opens.

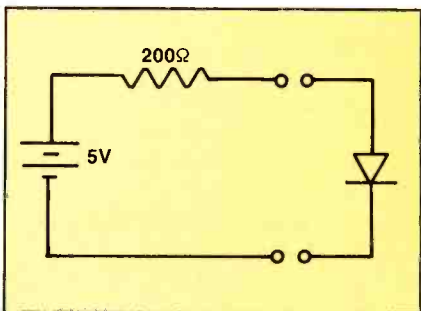

Figure B. The silicon diode to be connected across this circuit has a maximum-value rating of 50mA at 2V. How much current will flow when the diode is connected into the circuit?

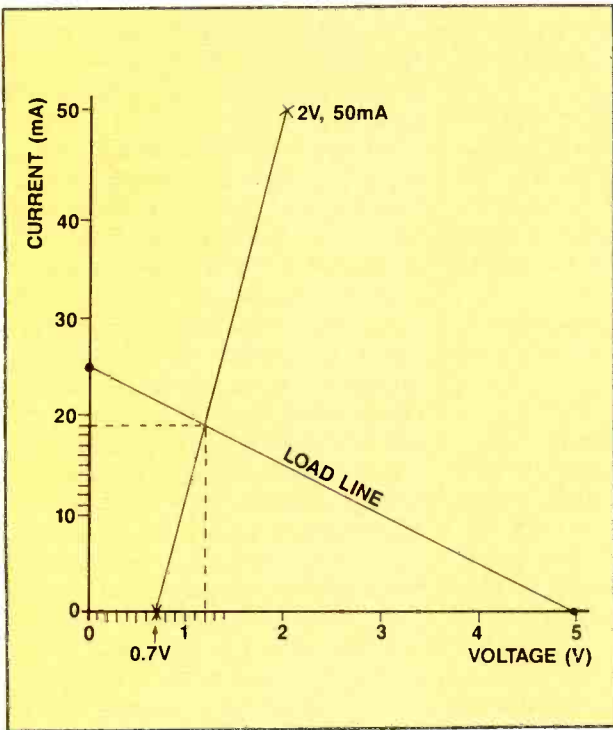

Figure C. To solve the question related to Figure B, you need to draw a graph showing the breakover point (0.7V) and the maximum value of 2V at 50mA. The load line is drawn between the 5V open-circuit voltage and the (5/200)mA short-circuit current.

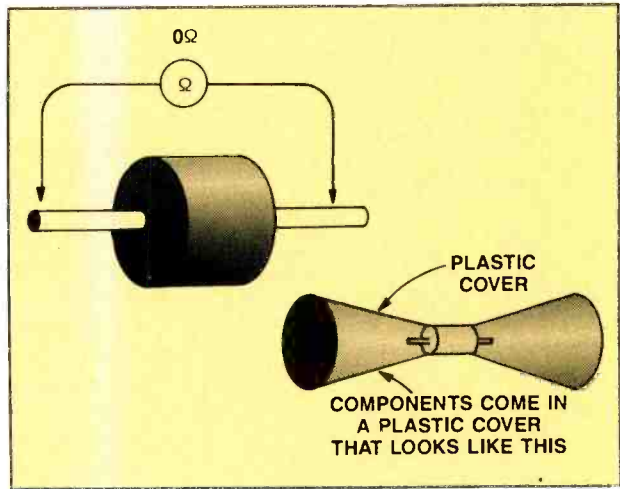
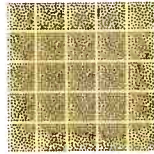

Figure D. Although the author doesn't know what these components are, they might be conductors that patch between two connectors. They could also be used as fuse-like holders to connect circuits. Using these devices, it is also easy to disconnect circuits in various places.



dangerous practice of putting solder in your mouth. As a general rule, you should not use your mouth as a third hand.

Another serious problem is related to smoke from the solder. There are some solders that contain cadmium.

**Come Out of the Dark.**

Make a new "connection" at the 1989 National Professional Electronics Convention & Trade Show, August 7-12, in Tucson, AZ. Programs will include:

- Managerial and Technical Seminars
- Instructor's Conference and Trade Show
- Meetings with Manufacturers' Reps

For a registration packet and more information, rush the following to NESDA:

Name \_\_\_\_\_

Address \_\_\_\_\_

City \_\_\_\_\_ State \_\_\_\_\_

Zip \_\_\_\_\_

Phone \_\_\_\_\_

**National Electronics Sales & NESDA**  
Service Dealers Association  
2708 W. Berry St.  
Ft. Worth TX 76109  
(817) 921-9061

\*One of a series.

**NEW VHS VU-THRU**  
DIAGNOSTIC TOOL

TECHNICIANS' TIME SAVER

The new VU-THRU is a clear jig that allows operation of a VHS machine as if there were a tape in it. It lets you instantly see the problem. Cuts diagnostic time to a minimum.

- 1 Same length as VHS Cassette
- 2 Same width as VHS Cassette
- 3 See thru area contact switches
- 4 Stop points
- 5 Centering key slot
- 6 Door switch relief
- 7 Same height as VHS Cassette
- 8 Tape pick up finger clearance

ONLY ... **\$14.95**  
each plus shipping

Call Toll FREE ...  
**1-800-558-9572**  
In Wisconsin 1-800-242-9553

Ask for your FREE copy of our 1989 Catalog with over 12,000 electronic parts and accessories.

P. O. Box 28 • Whitewater, Wisconsin 53190

Circle (18) on Reply Card

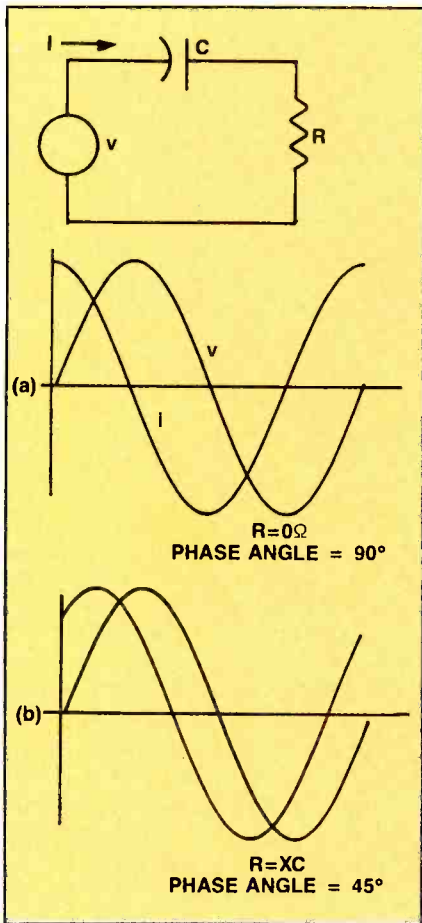

**Figure E.** When you compare the waveforms in (a) and (b), you can see that adding resistance reduces the phase angle between the applied voltage and the resulting current. To get the full  $90^\circ$ , you would have to reduce the resistance to  $0\Omega$ . However, that would reduce the output voltage (across R) to  $0\Omega$ .

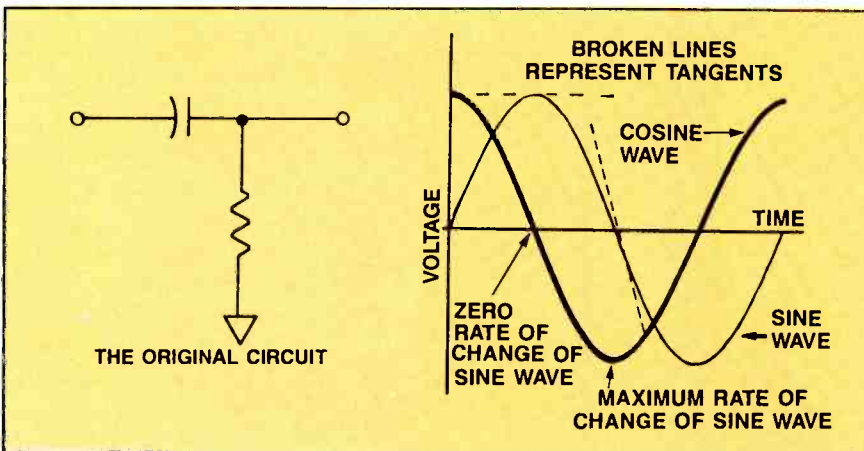

**Figure F.** When a sine wave is applied to a differentiating circuit, the output is a cosine wave for three reasons:

- the amplitude of the output wave will be maximum when the rate of change of the sine wave in the positive direction is at a maximum (when the slope of the curve is steepest upward, which occurs when the sine wave amplitude is increasing through the zero voltage point).
- the amplitude of the output wave will be minimum when the rate of change of the sine wave in the negative direction is at a maximum (when the slope of the sine curve is steepest downward, which occurs when the sine wave amplitude is decreasing through the zero point).
- the amplitude of the output wave will be zero whenever the rate of change of the sine wave input is zero, which occurs at the instant when the sine wave is at its maximum value.

The waveform that fits this description and is continuous between these points is a cosine wave.

**TECHNICIANS HAVE DIED FROM INHALING SMOKE FROM THOSE SOLDERS.**

You could argue that they did not solder in a place with enough ventilation. You could also argue that the technicians did not follow good practice when they inhaled the smoke into their lungs. You would probably be right in both cases.

The purpose of this discussion is to motivate you to examine your own soldering techniques.

### More on differentiating circuits

When you were in kindergarten, your teacher told you that the current/voltage relationship of a capacitor is easily explained. Because the current has to flow into the capacitor before there can be a voltage across it, the current leads the voltage.

That, of course, is a model of circuit behavior that won't stand up to our own critical test. (However, it is a good way to remember that current leads the voltage in a capacitive circuit.)

When you compare the waveforms in Figures E(a) and E(b), you can see that adding resistance reduces the phase angle between the applied voltage and the resulting current.

Also, to get the full  $90^\circ$ , you would have to reduce the resistance to  $0\Omega$ . However, that would reduce the output voltage (across R) to  $0\Omega$ .

So, true differentiation is NOT possible with the R-C circuit because of the physical characteristics of the circuit parameters.

Let's go back to the previous issue. Figure F is taken from that discussion. It shows a sine wave and a cosine wave on the same time base. Also shown is the simple R-C differentiating circuit from that discussion.

You will remember that the voltage across the resistor in Figure F is dependent upon the current through it. (That current, in turn, depends upon the rate of change of applied voltage.)

In mathematics, you get a cosine wave when you differentiate a sine wave. The value of the cosine wave is, at all points, related to the rate of change of the sine wave. The cosine wave is  $90^\circ$  out of phase with the sine wave.

In the real world, the voltage across the resistor cannot be  $90^\circ$  out of phase with the applied voltage. Instead, it must always be less than  $90^\circ$ .

As was illustrated in Figure E, the lower the resistance value, the closer to  $90^\circ$  is the phase difference between the applied voltage and resulting current.

You can get very close to a cosine wave across the resistor by making its resistance very low. That also means a low voltage, but that voltage can be amplified. For practical purposes, that gives a differentiated sine wave.

After trying to visualize the waveforms in the simple R-C circuit, you will, no doubt, come to the conclusion that there has to be a better way to explain this.

One way is to develop more math and then go from there. That is my personal preference. However, our present school system spends a lot more money on discipline and control than it does on inspiration. As a result, many technicians have shied away from math, regardless of the fact that it helps you visualize circuit behavior.

Rather than try to force math down everyone's throat, next month I'll take a completely different tack.

Graphical solutions are, by far, the easiest way to represent problems like this. With a few triangles, you can see exactly what the relationship is for the circuit voltages and current.

That, in turn, will get us much closer to understanding how the differentiating circuit reacts to a sine wave. Then, we will look at the amplified version that works much better than the simple R-C version.

**ES&T**



# Choosing the right software

By William J. Lynott

Last month we reviewed some of the basics you need to consider when you're buying computer hardware suitable for an electronics service company. As important as choosing hardware is for computerizing your business, it takes a back seat to the importance of selecting software.

Software, as you know, is the term given to the programs that tell your computer what you want it to do and how to go about doing it. For the most part, computer hardware tends to be of a standardized and predictable quality. As I said last month, as long as you get the right configuration, you're not likely to go wrong with any of the popular brands. Software, however, is another matter. There is a lot of both good and bad software out there.

Because software provides specific direction to your computer, it must be tailored to provide precisely the things you need to help run your business. Even within the electronics service industry, there are vastly different ideas among service dealers about what software should do. That's what makes it so important that you select the right software package. If your software doesn't do what you expected, your system will be an expensive disappointment.

### Custom, generic or off-the-shelf?

There are three choices when it comes to buying software: custom programs written specifically for you by a computer programmer (often the best choice); generic software written specifically for service businesses (much less expensive and often quite good); and off-the-shelf software (the least expensive, but it requires a considerable investment in learning time).

Unless your service business is relatively large (more than \$500,000 or so in annual gross), hiring a programmer to write a custom program for you probably isn't a practical alternative. A good custom program will usually run into thousands of dollars.

Lynott is president of W.J. Lynott, Associates, a management consulting firm.

Most electronics servicers will find either generic or off-the-shelf commercial software the best choice. Let's discuss each briefly.

A few years ago, specialized software written for service businesses was scarce. What was available was first-generation work that often left a great deal to be desired. Some of it was almost totally worthless. The result: A lot of service entrepreneurs were left sadder but wiser.

Fortunately, that picture has changed. The free market has gradually weeded out most, if not all, of the below-par

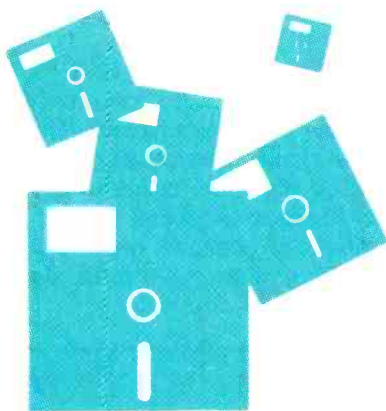

material. What is left is largely second- and third-generation software that has withstood the test of time. I've had the opportunity to review many of the service management programs on the market today. Most of the ones I've seen do their jobs well. Several companies now offer programs written specifically for electronics servicers. Some of these advertise regularly in this and other trade journals.

When it comes to generic software, caution is the byword. Before you buy, I recommend that you ask whether a demonstration version is available. Many companies have put together demonstration disks that allow you to preview the program's major features without actually buying it. And any legitimate software company will be able to refer you to satisfied users with whom you can check.

Off-the-shelf software systems are generic programs such as word pro-

cessors, database managers and electronic spreadsheets. Although each will require some effort on your part to learn, they offer considerable flexibility and are the least expensive way to computerize the major parts of your service operation.

### Which software to choose

The typical small electronics service company could take care of most of its software needs with two types of off-the-shelf software: a database manager and a spreadsheet program.

An electronic *spreadsheet* enables you to manipulate numbers. Anything to do with the financial aspects of your business, such as budgets, operating statements and technician productivity, can be handled by a good spreadsheet. I use and recommend the all-time best-seller, Lotus 1-2-3, for this purpose. Today, however, there are several lower-priced products that have most or all of the same features. Quattro is one of the most popular of those.

*Database managers*, on the other hand, are excellent for maintaining your customer records and your repair-parts inventories. As the name suggests, database managers are programs designed to store and retrieve data of almost any type. After reviewing many database managers, I settled on dBase III Plus, the leading product of its type. (dBase IV has recently been introduced.) As with other classifications of software, though, competing products with similar features are now available for less money. Good database managers and spreadsheet programs are generally available at list prices in the \$300 to \$500 price range. However, remember that heavy discounting is prevalent in the software trade.

Computerizing your service business isn't going to solve all of your management problems. Far from it. Actually, experience shows that companies already well-managed stand to benefit most from computerization. If you're ready for it, introducing a computer into your business has never been easier or less expensive.

ES&T

# Audio output problems? Maybe it's ESR.

By Robert Arso

If you're troubleshooting a capacitor-coupled audio output circuit that doesn't seem to be delivering the amount of power for which it was designed, check the output capacitors. Over time, the electrolyte in these large capacitors can dry out, which, along with other aging effects, can cause their resistance to increase. The increased resistance of the capacitors, in turn, causes the circuit's performance to deteriorate.

Figure 1A represents a typical audio output circuit. The circuit element marked ESR represents the *equivalent series resistance* of the capacitor. We'll discuss ESR in detail later. For now, take a look at Figure 1B, a plot of the ESR power curve. As the frequency increases, the capacitive reactance of the

Arso is chairman of the electronic technology department at Bismark State College.

capacitor decreases. The circuit current then increases. Consequently, the power dissipated in the ESR increases. The result is a reduction in output power, which reduces the design efficiency of the circuit at higher frequencies.

Another problem: When ESR is too high, the internal temperature of the capacitor rises. The higher temperature dries up the electrolyte, which tends to cause a decrease in component life and value.

### The definition of ESR

Capacitors are used extensively in consumer electronics circuits. They're used to block dc current while passing ac when stages are coupled together. They shunt ac to ground in other applications to eliminate negative feedback. They're also used in the output

stages of audio equipment. Real capacitors, as opposed to ideal capacitors, exhibit some degree of resistance in addition to their capacitance. This equivalent series resistance, or ESR, exists because all capacitors have resistance in the leads, in the connecting points where the leads connect to the plates, and in the dielectric and the electrolyte. The sum of these resistances is the ESR.

As long as a capacitor is within its design tolerance, the circuitry it's in operates properly. When the ESR increases to an unacceptable level, the resistive effect of the capacitor may be the source of effects that cause the performance of the product to deteriorate.

Figure 2 shows the relationship of the current and voltage in a resistor. Notice that the two waves are in phase and that their product (voltage times current) is always positive. The positive power curve indicates that all of the power delivered to the load is dissipated by the load, and none of the power is returned to the voltage source.

An ideal capacitor, on the other hand, does not dissipate any power. The phase shift between the voltage and the current is 90°. Figure 3 shows the relationship of voltage, current and power in a pure capacitor. Notice that the positive and negative power curves are equal in area to each other. In this situation, no power is dissipated.

Now let's look at a capacitor that has an acceptable amount of equivalent series resistance at its lowest operating frequency. A majority of this resistance is made up of two sources: the evaporation of water from the electrolyte, and the mechanical connections between the component leads and the capacitor's plates.

The opposition that a capacitor presents to an alternating current flow — and which causes the voltage drop across the capacitor — is called *capacitive reactance* and is inversely

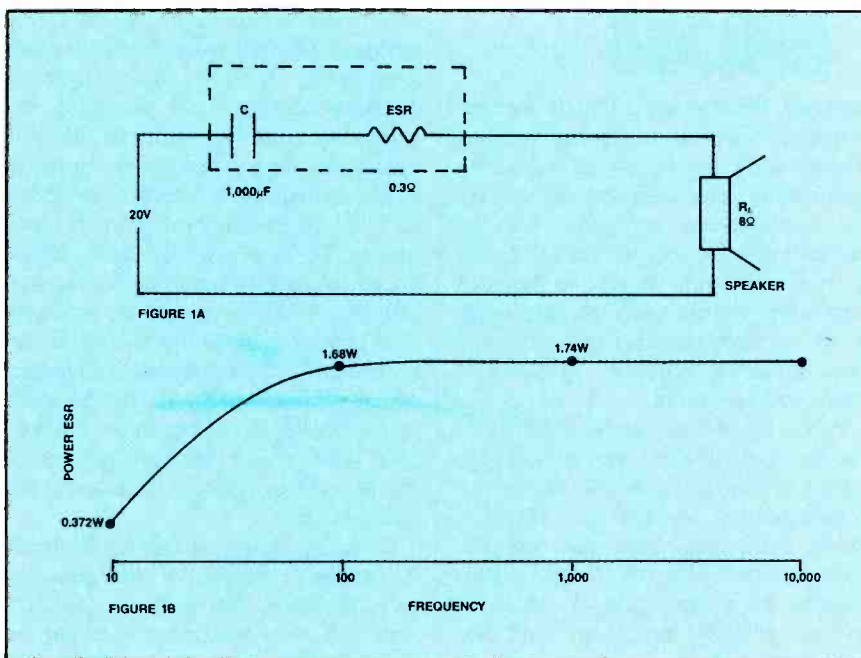

**Figure 1.** Figure 1A represents a typical audio output circuit. The circuit element marked ESR represents the *equivalent series resistance* of the capacitor. Figure 1B is a plot of the ESR power curve. As the frequency increases, the capacitive reactance of the capacitor decreases. The circuit current then increases, and consequently the power dissipated in the ESR increases. The result is a reduction in output power.

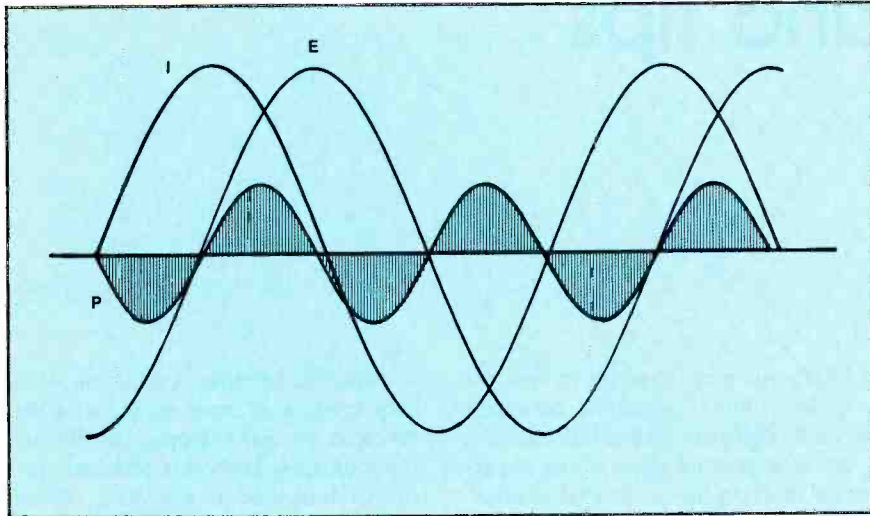

**Figure 2.** This graph of the phase relationship between voltage and current in a resistor shows, through the positive power curve, that power is being dissipated in the resistor.

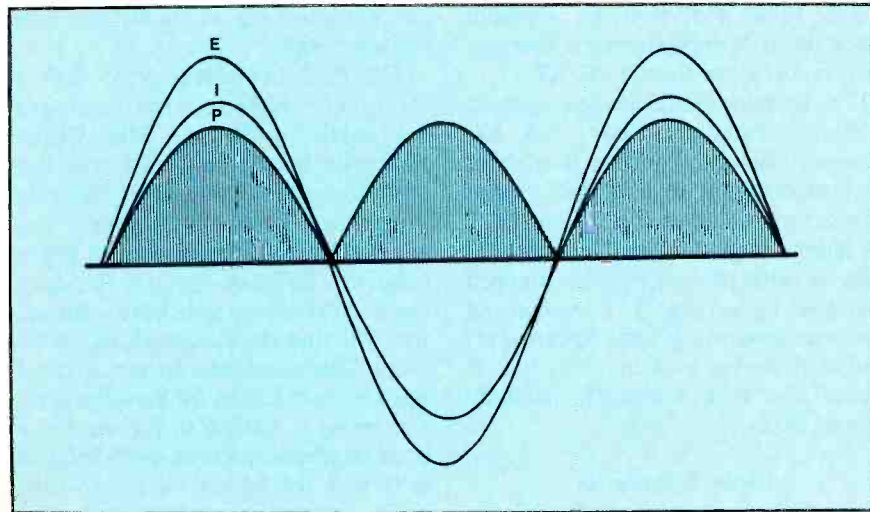

**Figure 3.** In this phase relationship between voltage and current of an ideal capacitor, the alternate positive and negative power curve indicates that no power is dissipated in the capacitor.

related to frequency. At relatively low frequencies, the capacitive reactance should be large in comparison to the ESR. This allows the capacitor to look almost like an ideal capacitor with very little power loss. As the frequency increases, the capacitive reactance decreases, and the ratio of the ESR to capacitive reactance increases.

At the risk of oversimplifying the case, as frequency increases, the voltage drop across the capacitor should decrease. In a properly designed circuit, it would approach a short circuit. However, if the ESR has increased because of capacitor aging, the voltage

drop (and therefore the power dissipation across the ESR) can be appreciable. Therefore, as capacitors age and their ESR increases, appreciable power is dissipated in the capacitor.

In an audio output circuit, the result is that the power available to the speaker can decrease and, therefore, the output of an audio system can gradually deteriorate. When you encounter a product in which audio output has unexplainedly decreased and preliminary checks don't reveal any problems, pull the output capacitor(s) and check them for ESR. Replace any that are out of tolerance.

**ES&T**

## ELECTRONICS WAREHOUSE CORP.

- Over 20,000 Electronic Items in stock
- TOLL-FREE "800" Phones
- 24 Hour hot line automatic order taker
- Same day order processing & shipping
- VISA & MASTER CARD accepted

### B & K TEST EQUIPMENT SPECIALISTS...

*We'll Beat Any Advertised Price*

#### ★ SPECIAL OFFER ★

Clip this ad and send it in with your order for ANY B & K TEST EQUIPMENT purchase over \$100 and deduct an additional **\$10** from our guaranteed lowest prices!

(offer expires July 15, 1989)

#### ATTENTION VCR REPAIRERS:

We stock 155 different VCR belt Kits, 47 different Video Heads, and 119 VCR Clutch Tire replacements, in addition to complete Idler Assemblies, Loading Gears, Sensing Lamps, and the most comprehensive Service Data inventory available anywhere!

Call or write for our latest 164 page money-saving catalog of values, and don't forget... We'll beat any advertised price on any B & K Test Equipment... Call us after you have shopped around and we'll prove it.



ORDER DEPT. ONLY

**TOLL FREE  
(800) 221-0424**

OTHER BUSINESS

—LOCAL—

(718) 375-2700

—FAX—

(718) 375-2796

**1910 CONEY ISLAND AVENUE  
BROOKLYN, NEW YORK 11230**

Circle (19) on Reply Card

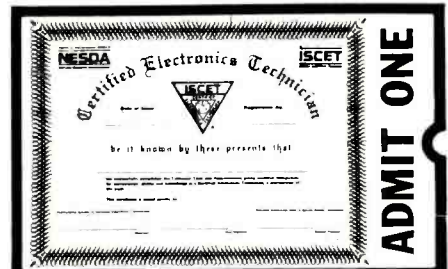

## Your Ticket To

# SUCCESS

Over 25,000 technicians have gained admittance worldwide as certified professionals. Let your ticket start opening doors for you.

ISCET offers Journeyman certification in Consumer Electronics, Industrial, Medical, Communications, MATV, Radar, Computer, and Video. For more information, contact the International Society of Certified Electronics Technicians, 2708 West Berry St., Fort Worth, TX 76109 • (817) 921-9101.

Name \_\_\_\_\_

Address \_\_\_\_\_

City \_\_\_\_\_

State \_\_\_\_\_ Zip \_\_\_\_\_

Send material about ISCET and becoming certified.

Send one "Study Guide for the Associate Level CET Test." Enclosed is \$5 (+ \$1 postage).

# Some hints and tips for IBM PCs

By Glenn R. Patsch

The Computer Corner column titled "Those Mysterious Glitches" in the May 1988 issue raised the question of why IBM PC/XTs sometimes exhibit strange behavior. As one who has worked on *many* IBM PCs, I know why some computers stop working. The IBM PC and PC/XT are especially sensitive to static shock, such as the kind you get



when you run across a carpet and touch something metal. Whenever the user touches the case of the PC or the keyboard and transmits even a small static shock, the computer is gone and must be restarted with the power switch. I have never seen a PC/AT or PS/2 exhibit this problem. The most common cause of static is the user walking across the room and touching the keyboard. Wearing a wool sweater and moving around a lot will also cause the problem.

---

Patsch is an electronics servicer at a Euclid, OH, servicing company.

---

That's one more example of how experience with a particular computer pays off. There are a lot of little oddities a servicer gets to know about a particular machine he services fairly often. For example, when PC operators power off the computer, they should wait for the power supply to fall below minimum voltage levels and drop the power-good signal before they turn the computer back on. IBM recommends a five second on/off cycle for the PC/XT.

The operator should not be concerned about whether the hard disk has stopped. However, it does take about five seconds for the hard disk to spin down, so listening for that is a good rule of thumb. If the hard disk has stopped, you know the power supply has dropped the power-good signal. I recommend that users count to 10 after powering off before powering back up. This rule of thumb also works with a PC with only floppy disks.

### Using diagnostics

For anyone servicing or working with IBM computers, I recommend they know about *The IBM Technical Directory*. The directory is free from IBM and lists the technical maintenance hardware manuals available. To order manuals or the directory, call IBM at 800-IBM-PCTB (800-426-7282) from 8 a.m. to 8 p.m. EST. IBM accepts Visa, MasterCard and American Express credit cards. You can also order the DOS technical reference manuals. The hardware maintenance manuals come with diagnostic software.

IBM always includes a diagnostic disk with the computer when it is new. The PC and PC/XT come with an operating manual and a diagnostics disk. This is a good place to start when something is wrong. The hardware maintenance and service manual, which is not included,

is invaluable because it tells you what those mysterious error numbers on the screen mean. For example, the 300 errors indicate a keyboard problem. Error 301 indicates no keyboard. When this message appears, the keyboard probably is not plugged in. The hardware maintenance manual also includes the advanced diagnostics disk, which lets you select any single test and save the test results.

The PS/2 computers come with a reference diskette that includes diagnostic software. The Quick Reference booklet included with the PS/2 computers has a brief "Solving Computer Problems" section. The booklet doesn't tell you this, but if you press the CTRL-A keys on the main menu of the reference diskette software, you will find the advanced diagnostic menu. This menu has a system checkout and low-level format for the fixed disk. The menu is hidden to prevent users from accidentally losing everything on their hard disk by low-level formatting it. Do not confuse low-level formatting with DOS's high-level format done by the DOS FORMAT command.

Because many problems with the PC often involve the hard disk or files, I find the Norton Utilities an invaluable tool. I highly recommend the newest Advanced Edition version 4.5. This version includes the Norton Disk Doctor, which is an all-in-one disk diagnostic program, and a Quick Unerase tool to unerase files. The DOS check disk (CHKDSK) command is probably the most under-used disk diagnostic software.

If you regularly service a particular make and model of computer, pay attention to its little idiosyncrasies. They can shorten your troubleshooting time and get you on to your next job. Using the right diagnostic tools can help you do it that much faster.

**ES&T**<sub>corp</sub>

## Books/Photofact

**Newnes Radio and Electronics Engineer's Pocket Book, 17th ed.,** by Keith Brindley; CRC Press; 201 pages; \$19.95.

This revised and expanded edition provides facts, figures and formulae useful to designers, students and service engineers in the radio and electronics industry. New sections on batteries, cables and connectors have been added, and the broadcasting information has been updated.

CRC Press, 2000 Corporate Blvd., NW, Boca Raton, FL 33431; 800-272-7737.

**Newnes Television and Video Engineer's Pocket Book,** by Eugene Trundle; CRC Press; 323 pages; \$19.95.

This reference book provides practical information on TV reception from VHF to SHF; display tubes; color camera technology; videorecorder and videodisk equipment; videotext and hi-fi sound (with picture) systems. Formal reference material, such as channel allocations, worldwide TV systems and videorecorder format specifications, is also included. The book concentrates on modern equipment. One chapter describes test instruments, fault-finding and repair techniques.

CRC Press, 2000 Corporate Blvd., NW, Boca Raton, FL 33431; 800-272-7737.

**VCR Troubleshooting & Repair Guide,** by Robert C. Brenner and

Gregory R. Capelo; Howard W. Sams, 256 pages; \$19.95.

This book provides guidelines for basic and advanced troubleshooting, preventive maintenance and repair of VCRs. The guide is designed for the electronics hobbyist, layperson or technician. More sophisticated service and repair functions are included for the service technician.

Howard W. Sams & Company, 4300 W. 62nd St., Indianapolis, IN 46268; 317-298-5722.

**Videocassette Recorders: A Servicing Guide, 3rd edition,** by Steve Beeching; CRC Press; 221 pages; \$39.95.

This revised and expanded edition includes material on the 8mm video format, VHS HQ and Super VHS. The chapter on fault patterns and component changes has been enlarged, and a new chapter covers VHS-C format, camcorders, JVC Videomovie, camera tubes, CCD photo-sensitive pickup devices and autofocus systems.

CRC Press, 2000 Corporate Blvd., NW, Boca Raton, FL 33431; 800-272-7737.

**PC Power Protection,** by Mark Waller; Howard W. Sams; 275 pages; \$19.95.

This text is a comprehensive treatment of electrical power and how it affects PCs. An overview of electricity is provided in non-technical terms and is supported by diagrams and illustrations.

The book explains how to protect PCs from sags, surges, brownouts, lightning and other damaging electrical problems.

Howard W. Sams & Company, 4300 W. 62nd St., Indianapolis, IN 46268; 317-298-5722.

**Understanding Magnetism: Magnets, Electromagnets and Superconducting Magnets,** by Robert Wood; TAB Books; 176 pages; \$10.60 paperback, \$17.95 hardbound.

This book, intended for general science readers and home experimenters, defines magnetism and geomagnetism and summarizes the discoveries that have shaped our understanding of magnetism and related electrical phenomena. Simple, illustrated experiments and projects allow readers to gain hands-on understanding of the role of magnetism in nature, science and everyday life.

TAB Books, Blue Ridge Summit, PA 17294-0850; 800-822-8138.

**How to Become a Successful Consultant in Electronic Servicing;** ATC Books; \$25.

This book discusses fees, ethics and professional advertising and shows the reader how to develop business plans, write contracts and locate clients. The book also discusses how to be a consultant.

ATC Books, 804 Jordan Lane, Huntsville, AL 35816; 205-895-9187.

**ES&T**

# STOP NEGLECTING YOUR VCR's

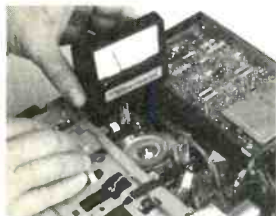

Tape Tension Gauge

Mechanical problems in VCR's cause approximately 75% of VCR malfunctions. Adjustments are necessary to keep your VCR equipment operating properly. Tentel gauges can help! They allow technical measurements to be made, even by non-technical people.

Tentel covers the entire mechanical performance of VCR's with easy to use, universal tools. These gauges are a MUST if your job includes VCR repair, and many non-technical users merely want to set up an effective preventative maintenance program.

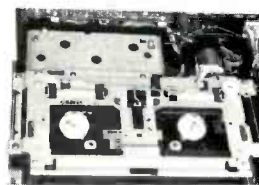

Spindle Height Gauge

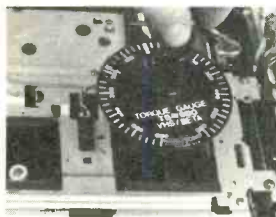

Dial Torque Gauge

Call now and find out how these four gauges can perform 28 critical measurements, including hold back tape tension, elevator latching, spindle height, guide height, various tape handling torques, video head tip wear and others, to help maintain or repair your VCR's.

**Tentel® Corp.**  
1506 Dell Avenue  
Campbell, CA 95008



Head Protrusion Gauge

**(800) 538-6894**  
In Calif. (408) 379-1881

Circle (15) on Reply Card

# Record problems? Check the safety-tab switch

By Stephen J. Miller

Defective safety-tab switches, especially intermittent ones, can cause a lot of headaches for servicers. The safety-tab switch tells the system-control microprocessor whether the record tab on the cassette loaded in the machine has been removed. Removal of the record tab on the videocassette will inhibit the record function. In most machines, the tab switch is open if the record tab has been removed and closed if the record tab is present.

Failure of this switch will naturally cause problems with recording. However, the symptoms will vary among the different models and manufacturers. Some machines will refuse to enter the record mode; others will enter play instead; some will even eject the cassette.

Although machines from several manufacturers have had intermittent safety-tab switch problems, we will focus on Matsushita machines. These machines are sold under a variety of brand names, including Panasonic, GE and Magnavox. In three recent model years of Matsushita machines, I have seen several cases of noisy or intermittent tab switches.

Each model year's machine has some unique symptoms when the tab switch is intermittent. Figure 1 groups the representative model numbers of the various brands into columns. All machines within a column are from the same model year and are either internally identical or very closely related. For simplicity, all examples will use the GE model numbers. The question mark signifies a wild card. Many different numbers may be inserted into the question mark spaces.

**Symptom: No timed recording**

In the GE 1VCR50??X models, an intermittent tab switch will cause the complaint of no timer or one-touch recording. If the resistance of the tab switch

	1985 line	1986 line	1987 line
GE	1VCR50??X	1VCR60??X	9-71?? 9-72?? 9-73??
Magnavox	VR84??SL01	VR85??SL01	VR95??AT01
Panasonic	PV-1225 PV-1525 PV-1530	PV-133? PV1535	PV-136? PV-1560 PV-146?

Figure 1. VCRs sometimes display intermittent safety-tab switch problems. As an example, the author looks at the unique symptoms exhibited in different model years of Matsushita VCRs.

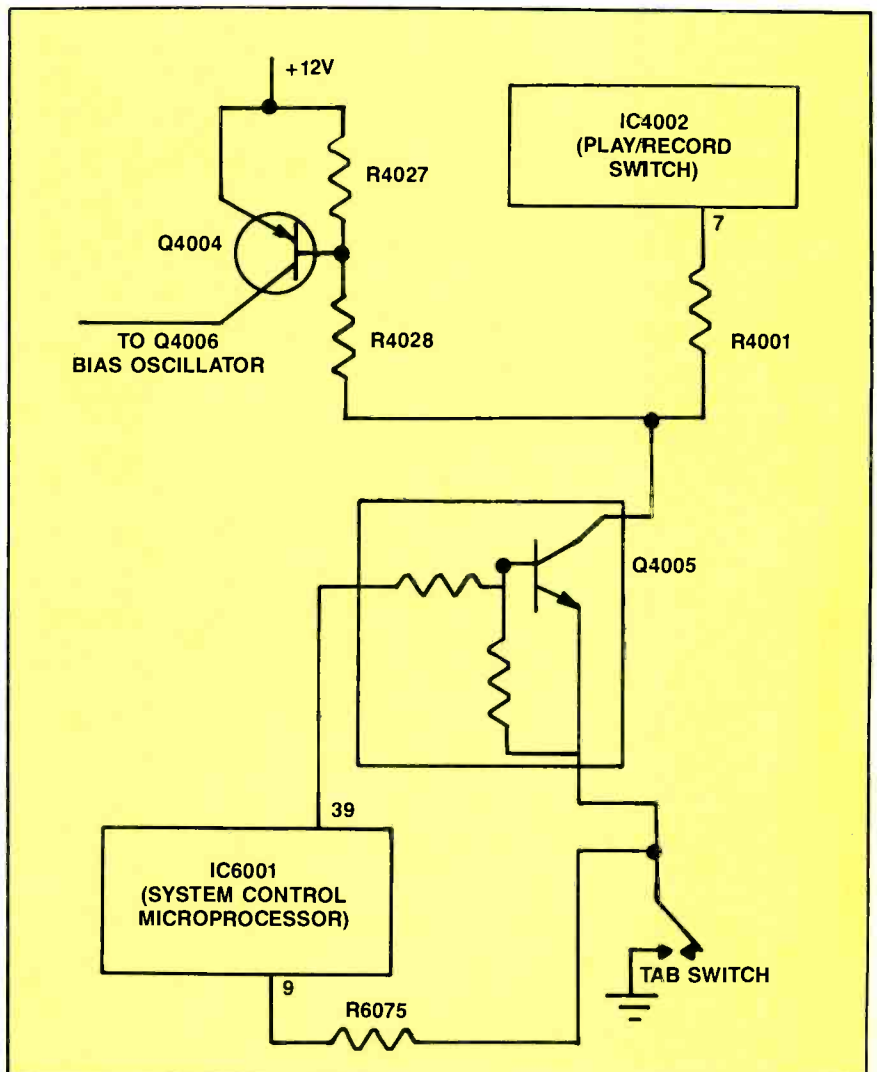

Figure 2. This partial schematic of the 1VCR60??X helps explain how only the audio can be affected.

Miller is a senior bench technician for a Lancaster, PA, repair company.

increases during timed recording, the unit will unload the tape and power itself off. However, if the resistance increases during regular recording, the unit will still continue to record normally. During regular recording, the tab switch is monitored only until loading is complete. After loading is completed, the status of the tab switch is ignored. This quirk causes some diagnostic problems for the servicer because regular recording will work fine on the test bench. Yet when the customer tries timed recording at home, the unit will fail. Be aware of the quirk when servicing these machines.

#### Symptom: Reverting to play mode

The GE IVCR60??X displays a variety of odd symptoms when the tab switch is defective. Like the IVCR50??X, these machines will unload and power off if the tab switch opens up during any timed record function. If the switch opens up during regular recording, these units will revert to the play mode. The display will still indicate REC, but the unit will go into play. If the switch again makes contact, the unit will return to the record mode.

Another common complaint caused by a defective tab switch is that the unit intermittently records only a snowy picture and hissing sound, usually for only a few seconds at a time. This complaint would naturally lead the servicer to suspect an intermittent in the tuner or IF section. Actually, the unit is returning to the play mode. The snowy picture and absence of sound are caused by the full erase head erasing the tape, followed by reversion of the machine to the play mode before the tape can pass across the heads to be recorded.

#### Symptom: Audio problems

The IVCR60??X machines will also display audio record problems if the tab switch develops a high resistance. If the resistance of the switch falls in the range of  $0\Omega$  to  $650\Omega$ , the recorded audio will contain noise clicks and/or motor-boating. Resistance values between  $650\Omega$  and  $3,000\Omega$  will cause the unit to record new video and erase old audio, but it won't record any new audio. If the resistance exceeds  $3,000\Omega$ , the unit will revert to the play mode.

Figure 2, which shows a partial schematic of the IVCR60??X, will help explain how only the audio can be af-

ected. The tab switch is actually in two different circuits at the same time. The tab switch pulls pin 9 of IC6001 low via R6075 and thus instructs the system-control microprocessor, IC6001, that recording is allowed. It is also the ground return for Q4005, which turns on when it receives a high on its base from pin 39 of IC6001 (the audio-delay record pin), and when its emitter is returned to ground via the safety-tab switch. With Q4005 saturated, Q4004 turns on via R4028 and supplies power to the record-bias oscillator transistor, Q4006.

Q4005 also controls the record switching function of IC4002. When Q4005 is turned on, R4001 pulls pin 7 of IC4002 low, switching the IC into the record mode. If the resistance of the tab switch increases greatly, Q4005 will come out of saturation and turn off both Q4004 and IC4002. Tab-switch resistance values of  $650\Omega$  to  $3,000\Omega$  will cause IC4002 to switch to the play mode while keeping Q4004 turned on, thus maintaining the bias oscillator. This situation leads to the complaint that the unit erases old audio but will not record new audio. Tab-switch resistance values of less than  $650\Omega$  will result in erratic switching of IC4002 and complaints of clicks, drop-outs and motor-boating.

#### Symptom: Ejecting the cassette

The GE 9-71?? machines have a tab-switch circuit very similar to the IVCR60?? machines and thus suffer from nearly the same symptoms. One major difference is that the 9-71?? will eject the cassette if the tab switch opens when the record loading process begins.

Another difference is that the 9-71?? uses a different tab switch. Both the IVCR50??X and IVCR60??X use the tab switch part number VSMS0007. The 9-71?? series machine uses a tab switch part number VSMS0015. By stocking just these two switches, you can repair units over three different model years in more than six different brands. Cleaning these switches is a very temporary fix. Always replace a noisy or intermittent tab switch.

Because of the intermittent nature of these switches, I install a new one in any Matsushita machine with a record problem. These switches are relatively inexpensive, so I also make it a practice to routinely replace them in machines that are in for major service, such as video head replacement.

**ES&T**

## LEARN VCR

### CLEANING/MAINTENANCE/REPAIR

**EARN UP TO \$1000 A WEEK, WORKING PART TIME FROM YOUR OWN HOME!**



Secrets Revealed!

NO Special Tools or Equipment Needed.

EARN UP TO \$60 AN HOUR AND MORE!

THE MONEYMAKING OPPORTUNITY OF THE 1990's

If you are able to work with common small hand tools, and are familiar with basic electronics (i.e. able to use voltmeter, understand DC electronics)...

If you possess average mechanical ability, and have a VCR on which to practice and learn...then we can teach YOU VCR maintenance and repair!

**FACT:** up to 90% of ALL VCR malfunctions are due to simple MECHANICAL or ELECTRO-MECHANICAL breakdowns!

**FACT:** over 77 million VCRs in use today nationwide! Average VCR needs service or repair every 12 to 18 months!

Viejo's 400 PAGE TRAINING MANUAL (over 500 photos and illustrations) and AWARD-WINNING VIDEO TRAINING TAPE reveals the SECRETS of VCR maintenance and repair - "real-world" information that is NOT available elsewhere!

Also includes all the info you'll need regarding the BUSINESS-SIDE of running a successful service operation!

#### FREE INFORMATION

CALL TOLL-FREE 1-800-537-0589  
Or write to: Viejo Publications,  
3540 Wilshire Bl., STE 310  
Los Angeles, CA 90010, Dept. EST

Circle (21) on Reply Card

## ATTENTION TECHNICIANS

- ★ JOB OPENINGS
- ★ MONTHLY TECHNICAL TRAINING PROGRAM
- ★ BUSINESS MANAGEMENT TRAINING
- ★ SDC SATELLITE NEWS
- ★ CERTIFICATION
- ★ TECHNICAL SEMINARS

All of this in a nonprofit international association for technicians

FIND OUT MORE:



604 N. Jackson St.  
Greencastle, IN 46135  
1-800-359-6706





Knight 83YX123 sweep generator with manual, \$90; Knight 83Y145 RF signal generator with manual, \$35; Heathkit TC-2 tube tester, checks old tubes, \$60. Add shipping. *William F. Springman, 309 N. Lafayette, North Liberty, IN 46554; 219-656-3158.*

Tentelometer model TZ-H7-UM tape tension gauge, TQ600 torque gauge, Tentel model TSH-VF VHS spindle-height gauge, Tentel model HPG-1 head protrusion gauge, SI stand, complete set for \$1,100. All in excellent condition, less than 6 months old. *Brett Mayes, 607 W. Copper, Butte, MT 59701; 406-782-2796.*

Sencore VA62 video analyzer and SC61 waveform analyzer, like new, in original boxes with all leads, schematics and manuals, \$4,200; also many other items: B&K, Heath, Tektronix. No collect calls. *Jeff Fischhorn, 9820 SW 159th St., Miami, FL 33157; 305-233-6040.*

Heathkit model 10-4560 oscilloscope with manuals and probes, nearly new, asking \$80 plus shipping. *Richard Church, Dick's Electronics, 1020 W. Hwy. 80 SP 29, El Centro, CA 92243.*

Sams Photofacts, #600 through #1700; Uniden 6000, 5000, 1000 satellite receivers; QST, CQ, 73 magazines; test equipment; Quasar modules; Sylvania test jigs. Send SASE for list. *Chequamegon Electronics, 917 MacArthur Ave., Ashland, WI 54806.*

Owner relocating — service manuals (Sams, Quasar, NAP), test equipment, tubes, parts inventory, 41-inch TV, office equipment, van, building, land, many misc. items. Building adaptable to many uses; great hunting and fishing area. Send SASE. *R.N. Yasko, Fremont TV, 407 E. Main St., Fremont, WI 54940; 414-446-2239.*

Shop closing — VCR test kit, RCA test jig (10J106A) and adapters for RCA TVs, microwave leakage tester, all for \$500. Call for other items for sale. *Charles R. Woodward, 3133 Eighth St., Meridian, MS 39301; 601-482-3995.*

Collectors items: Rider perpetual service manuals, abridged volumes I through V; volume I and volumes VI through XIX. Best offer. *Paul Townsend Electronics, P.O. Box 501, Ashton, IL 61006; 815-453-2338.*

Sencore VA62 w/acc., NT64 pattern generator, TF46 Super Cricket, 143 CRT tester w/book, DVM 36 digital meter w/book, Hybrid tube/trans. checker, B&K 1210 color generator, B&K 1827 frequency counter, Sly testing jig with more than 40 hookups, Zenith model 852-257 SYS analyzer RCA-fiche card set, Hitachi scope V-152F 15MHz. Packaged deal, \$5,000. *Tim Gruber, Tim's TV Service, 3502 Cheraz Road NE, Albuquerque, NM 87111; 505-296-6449.*

Sencore model 700 tube tester; Sencore model TR139 transistor tester; Conar model 250

oscilloscope; NRI model 311 professional resistor-capacitor tester; one set (24 volumes) Supreme radio manuals. *Elmer J. Alderman, Route 2 Box 139, Madison, NC 27025.*

B&K-Precision Deluxe Precision model 1260 NTSC video generator, never used, in box, \$1,000; B&K model 467 CRT restorer/analyzer with new extra sockets, used 10 times, \$400; Tektronix model 2246, 100MHz, in warranty, with two probes, used one week, \$1,650. Add UPS — money order, cashiers check only. *Robert E. Duncan, 1513 Sixth St., Eureka, CA 95501; 707-442-2794 7 p.m. to 11:30 p.m. PST.*

Estate sale — misc. electronics, test equipment, hi-fi, audio gear. Send SASE for list. *JDM, 1331 Thousand Oaks Blvd., Albany, CA 94706.*

Sencore SC61 video analyzer in unopened factory carton, just returned from Sencore factory — updated and calibrated, \$2,200. *Ruddy Olliphant, 9785 S.E. Hwy. 42, Summerfield, FL 32691; 904-245-8786 evenings.*

B&K model 2120 20MHz dual-trace oscilloscope, almost new, in box, with accessories and cables, \$350; B&K model 1246 digital IC color generator with leather case, very good condition, \$65. *Donald Miller, Solid State TV, 102 E. Aurora St., Ironwood, MI 49938; 906-932-1919, no collect calls.*

**ES&T**

## Classified

Advertising rates in the Classified Section are \$1.65 per word, per insertion, and must be accompanied by payment to insure publication.

Each initial or abbreviation counts as a full word.

Minimum classified charge \$35.00.

For ads on which replies are sent to us for forwarding (blind ads), there is an additional charge of \$40.00 per insertion to cover department number, processing of replies, and mailing costs.

Classified columns are not open to advertising of any products regularly produced by manufacturers unless used and no longer owned by the manufacturer or distributor.

### FOR SALE

**VHS-VCR Repair Solutions Volumes I, II, III, IV.** Each contains 150 symptoms and cures, cross reference chart, free assistance. Each \$11.95, any two \$19.95, any three \$29.95, all \$39.95. *Eagle Electronics, 52053 Locks Lane, Granger, IN 46530. 01-89-TFN*

**TV/VCR TUFF TIPS** listed by mfg. & model. Over 400 tips. \$21.95. TV Tips only \$11.95, VCR Tips only \$13.95. **CROSS-REFERENCE** listing for electronically similar manufacturers, RCA, GE, Sylvania, Panasonic, Quasar, Magnavox, Philco, & J.C. Penney, \$19.95. **TV/VCR FAILURE HISTORIES.** Multiple cures for most problem areas. Send \$7.95 with mfg. and model number. Money will be refunded with free sample if model is not on database. Add \$1.50 postage and handling. **TECH CURES, 4825 Fredericksburg Road, San Antonio, Texas 78229. 12-88-TFN**

**NEED A TORQUE METER?** I built one for free, you can too, easily. Plans \$4.00. Anything Electronic, Route 3, Box 180, Brandenburg, KY 40108. 6-89-11

**REDUCED 75%,** Diehl Mark V scanner \$249, Diehl Mark III scanner \$99. New. 2805 University Ave., Madison, Wis. 53705, 608-238-4629, 608-233-9741. 3-89-ftn

**TV TROUBLESHOOTING:** Over 300 problems/solutions. Nothing old listed. \$12.00, add \$1.50 shipping. Refund if not satisfied. *Jones Electronics, Box 702, Niceville, FL 32578. 6-89-TFN*

**1989 CRT SETUP/REFERENCE BOOK,** for use with our "Universal CRT Adapter". Lists "Pinouts" on heaters, cathodes, G1's & G2's for ALL Color, Projection, Oscilloscope and Camera Pickup CRT's from 1949 thru 1989. (Foreign & domestic) No COD's. \$11.00. Chargecards/Checks. **DANDY MFG. CO., 2323 Gibson St., Muskogee, Ok. 74403. 918-682-4286. 6-89-11**

**ZENITH DATABASE PROGRAM.** Save time on service calls. Cross reference Zenith System 3 Model #'s to module complement. Runs on IBM and compatibles. \$49.00 for uncompiled version (requires dbase or compatible software), \$79.00 for stand alone program. Send to Milliani TV, 94-515 Ukee St. #11, Waipahu, HI. 96797. 6-89-11

**TV DOUGH DOGS:** 300 symptoms and cures. Send \$8.95 to DAVIS TV, 11772 Old Fashion Way, Garden Grove, CA 92640. 10-87-tfn

**PHOTOFACTS:** Folders under #1400, \$4.00. Above #1400, \$6.00. Sent same day first-class postpaid. *Loeb, 414 Chestnut Lane, East Meadow, NY 11554. 6-89-3t*

**ELECTRONIC COMPONENTS:** Free 192 page catalog including capacitors, resistors, relays, connectors, soldering equipment and supplies. **MOUSER ELECTRONICS. 1-800-992-9943. 6-89-11**

### SERVICES

**SPEAKER REPAIR.** 4"-18" Speakers reconed. Cross-over parts. *Orban Audio, 119 7th St. NW, North Canton, Ohio 44720, (216) 497-9932 6pm-9pm EST. 4-89-ftn*

### HELP WANTED

**CENTRAL FLORIDA REPAIR SHOP** needs an experienced video/audio visual service technician. Send resume to Blumberg Communications, Inc., 7101 Presidents Drive, Orlando, Florida 32809, attn: Service Dept. 5-89-21

### BUSINESS OPPORTUNITIES

**TV SERVICE SHOP/VCR** tape rental in the Florida Keys fully equipped, 11 year owner retiring. Ray at Coldwell-Banker (305) 872-3050. 6-89-11

**VCR SERVICING BUSINESS IN MONTEREY, CA.** Only one. Can be expanded. Great lease with apartment. Owners leaving area. \$39,500. Beautiful beaches, great schools & clean air! Agent 408-625-5581. P.O. Box 4335, Carmel, CA. 93921. 6-89-11

**BE YOUR OWN BOSS—Audio/Video/TVRO** sales and service. Perfect small business for 1-2 man operation. Profitable Colorado business. Low overhead, owner can finance. 303-867-3554. 6-89-21

**T.V. VCR SERVICE BUSINESS** and four story building with living quarters. Located in Balto, Maryland. Call 1-301-467-0075. 6-89-11

**ELECTRONICS BUSINESS:** very diverse, factory sys contracts, installations for major dealers, growing security dept., all equipment & truck included, \$55,000. *Northern N.J. 201-575-6217. 6-89-3t*

**WHY PAY SENCORE \$1295?**

TEST/CLEAN/RESTORE with a UNIVERSAL CRT ADAPTER that fits all CRT testers and quickly hooks-up to all CRT's on the market (now or in the future). Guarantees profit & total CRT servicing. Used by TV Repair, US Govt., Airlines, Computer Serv., Dept. of Defense. Patented Adaptor-Sockets-CRT Reference/Setup book—Only \$59.95 plus \$2.50 postage & handling. Our 6th year. Over 15,000 sold. Chargecards/Checks/COD. Money Back Guarantee.

FREE CALL 1-800-331-9658  
DANDY MFG. CO./RANDALL ELECTRONICS  
(918) 682-4286, 2323 Gibson St., Muskogee, OK 74403

Circle (22) on Reply Card



**"Tech's Guide To Pricing"**  
updated new 5th edition... a framework for setting rates that apply to Hi-Tech products... a formula that guarantees SUCCESS!  
Call Toll Free for details 1-800-228-4338 8/5 CST

Circle (23) on Reply Card



**Moving?**  
Take us with you.  
Just peel off your subscription mailing label and attach it to the address change card inside this issue. Please allow 6-8 weeks to process your address change.

# Ad Index/Hotline

Company	Page Number	Reader Service Number	Advertiser Hotline
Amprobe Instrument	IBC	2	516/593-5600
B&K Precision Dynascan Corp.	15	9	312/889-1448
Beckman Industrial Corp.	17	10	619/495-3200
Createc Signal Computer	21	12	800/222-2688
Dandy Mfg. Co.	68	22	800/331-9658
Electronics Warehouse Corp.	61	19	800/221-0424
ETA	65		
Fluke, John Mfg. Co., Inc.	5	6	800/227-3800
Genstar Rental Electronics	49	25	800/227-8409
Iscet	61		
Kenwood Test & Measuring Instruments	51	24	213/639-4200
Leader Instrument Corp.	3	4,5	800/645-5104
MCM Electronics	23	13	800/543-4330
Mitsubishi	1	3	800/553-7278
Nesda	21, 57		
Parts Express Int'l., Inc.	43	16	513/222-0173
Philips ECG	7	26-29	800/225-8326
Prime Electronics	57	18	414/473-4727
Sencore, Inc.	IFC	1	800/843-3338
Sperry Tech, Inc.	68	23	800/228-4338
Tektronix, Inc.	8-9,8A-8B	7	800/835-9433
Tentel	63	15	800/538-6894
Test Probes	27	14	800/368-5719
Tool Kit Specialists, Inc.	45	17	800/621-0854
Tronix, Inc.	41	20	313/939-4710
U.S. Instrument Rentals	19	11	800/824-2873
Viejo Publications	65	21	800/537-0589
Zenith	BAC		

**ADVERTISING SALES OFFICES**

## ELECTRONIC

*Servicing & Technology*

**KANSAS CITY, MISSOURI**

Greg Garrison, Sales Manager  
P.O. Box 12901

Overland Park, KS 66212  
Phone: (913) 888-4664

Fax: (913) 541-6697  
Telex: 42-4156 INTERTEC OLPK

**OXFORD, ENGLAND**

Nicholas McGeachin  
Roseleigh House, New Street

Deddington, Oxford OX5 4SP  
Phone: (0869) 38794

Telefax: (0869) 38040  
Telex: 837469 BES G

**TOKYO, JAPAN**

Mashy Yoshikawa

Orient Echo, Inc.

1101 Grand Maison

Shimomiyabi-Cho, 2-18

Shinjuku-ku, Tokyo 162, Japan

Tel: 03-235-5961

Telex: J-33376 MYORIENT

**FREWVILLE, SOUTH AUSTRALIA**

John Williamson

Hastwell, Williamson, Rep. Pty. Ltd.

109 Conyngham Street

Frewville 5063

South Australia

Phone: (08) 79 9522

Fax: 08 79 9735

Telex: AA87113 HANDM

# GO AHEAD... Make A Mistake

Fused to 600 Volts AC/DC to help protect instrument as well as user from mis-application

## MODEL AM-12 ▶

- 20 Industrial Ranges
  - .1Ω Resolution
  - Pocket Size
- Price: \$41.85



## MODEL AM-4B ▲

- .01Ω Resolution
  - Sensitive 20μ A/20Ω Ranges
  - Audible Continuity\*
- Price: \$104.85



## ◀ MODEL AM-14

- Direct Temperature Reading
  - 200mV & 20MΩ Ranges
  - Convenient Intermediate Range
  - Audible Continuity
- Price: \$64.35

**NEW**

## ALL MODELS INCLUDE

- Over Range Indication
- Low Battery Indication
- Auto Zeroes
- Reversed Polarity Indication
- Standard Banana Jacks
- PTC Protection to 500V AC/DC on all Ohms Ranges
- Fuse Protection to 600V AC/DC on all mA/μA Ranges

**AMPROBE INSTRUMENT®**  
DIVISION OF CORE INDUSTRIES INC. LYNBROOK, NEW YORK 11563

630 MERRICK ROAD, P.O. BOX 329  
Area Code 516-593-5600 • ITT TLX 4971416  
FAX 516-593-5682

Circle (2) on Reply Card

**For your own reputation  
and in your customers' best interest  
always insist on**

**Genuine Zenith**

---

**Remanufactured Replacement Parts**

---

**Reconditioned and Serviced for Reliability**

---

**by Zenith People**

---

**as Knowledgeable and Dedicated as**

---

**Those Who Made the Originals!**

---

One of the easiest, fastest, and surest ways for you to preserve the pedigree and maintain the quality of the Zenith products you service is with genuine Zenith replacement parts.

And at no time is this more critical than when you replace the more sophisticated components like modules, tuners, channel selectors and sub-assemblies.

Your participating Zenith parts distributor will supply you with a replacement remanufactured, reconditioned and serviced for reliability by Zenith people as dedicated and knowledgeable as those who made the original.

Equally important, the replacement module or sub-assembly you receive in exchange from your Zenith parts distributor

will most likely incorporate any Zenith factory-made modifications in effect at the time of remanufacture.

And nowhere else but in a participating Zenith parts distributor's Exchange Program can you get assurance that a replacement incorporates Zenith factory up-dates!

To learn the location of the Zenith R&R Exchange Counter in your area, write on your company letterhead and we will help you locate one that's nearby.

Risking an exchange for a Zenith replacement anywhere else doesn't make sense. Not when factory-fresh replacement modules and sub-assemblies are so readily available thru a Zenith parts distributor's Exchange Program! Write now!



The quality goes in before the name goes on.®